

**2020 Kentucky
State Plumbing Law,
Regulations and Code Book**



DEPARTMENT OF HOUSING, BUILDINGS & CONSTRUCTION

DIVISION OF PLUMBING

**500 Mero Street Floor 1
FRANKFORT KY 40601**

Phone: 502-573-0397

Website Address: dhbc.ky.gov/plb

E-mail Address: Plumbing@ky.gov

**UNOFFICIAL TEXT OF STATUTES AND
ADMINISTRATIVE REGULATIONS
FOR INFORMATIONAL ONLY**



Andy Beshear, Governor

**DEPARTMENT OF HOUSING,
BUILDINGS AND CONSTRUCTION**

Max Fuller,

Acting -Commissioner

DIVISION OF PLUMBING

**David J. Moore,
Jeff Hardin,
Dennis J. Rodgers,
Floyd Schanz,**

**Director
Field Operations
Field Operations
Field Operations**

Plan Reviewers

**Frank Blevins,
Mike McPherson,
Chris Quire,
Chris Stein,
Geno Washington,**

**Lexington Office
Bowling Green Office
Louisville Office
Florence Office
Frankfort Office**

AREA PLUMBING CONSULTANTS

<u>Area Supervisor</u>	<u>Area</u>	<u>Phone number</u>
David Beaven	A	270-314-0563
Alan Lush	B	502-262-9271
Mark Curry	C	270-589-1848
George Kelley	D	502-492-2661
Bryan Watkins	D	502-224-6930
Connell Powell	E	502-271-8601
Doug King	F	859-339-9152
DeWain Woolum	G	606-585-5579
Rodney Adams	H	606-359-3851
Matt Lewis	I	859-327-2191
Mark Hayden	J	270-339-0867

AREA COMPLIANCE

Jeff Phelps	East	606-224-9188
--------------------	-------------	---------------------

Area Plumbing Inspectors

Area A	David Beaven - Supervisor	
John Baird	Jerry Dorris	Roy McGregor
Anthony Mattingly	Mark Thomas	

Area B	Alan Lush - Supervisor	
Mike Haycraft	Bob Maeser	Dale Osborne
John Willis		

Area C	Mark Curry - Supervisor	
Jason Collins	Mark Long	David Mercer
Earl Sandusky	Ricky Stamper	Charlie Stearns

Area D	George Kelley - Supervisor	
John Applegate	Tim Brightman	Michael Hagan
Trevor Lewis	Craig Meredith	Michael Sloan

Area E	Connell Powell - Supervisor	
Todd Haeberlin	Daniel Samuels	Kenny Thacker

Area F	Doug King – Supervisor	
Isaac Clark	Daniel Clem	Jimmy Issacs
Steven Long	Geno Washington	

Area G	Dewain Woolum - Supervisor	
Ricky Adams	Keith Center	Chris Ferguson
Lloyd Martin	Gordon VanHoose	

Area H	Rodney Adams - Supervisor	
Monroe Brown	Mike Doolin	Jeff Nolan
Rob Dowden	Joe Mike Wiese	

Area I	Matt Lewis - Supervisor	
Chris Stein	Tom Parrish	Patrick Kennedy
Jesse Long	Gary Jones	

Area J	Mark Hayden - Supervisor	
Kyle Bealmear	Lynn Bundy	Brad Erwin
Michael Murt		

Kentucky Revised Statues

KRS 318

Includes enactments through the 2020 Regular Session

The KRS database was last updated on 7-20-2020

**CHAPTER 318
PLUMBERS AND PLUMBING**

- **.010 Definitions for chapter.**
- **.015 Application of chapter and of state plumbing code.**
- **.020 Apprentices, maintenance men, water company or district employees exempt.**
- **.030 License and general liability insurance required.**
- **.040 Qualifications -- Examinations -- Reciprocity.**
- **.050 Fees.**
- **.054 License expiration -- Notice -- Renewal and revival fees -- Evidence of completion of continuing education -- Interim period for use of recently deceased owner's or employee's master plumber's license.**
- **.060 Reexamination.**
- **.064 Revocation or suspension of license.**
- **.066 Hearing -- Appeal.**
- **.077 Review and comment on amendments to code -- Appeals.**
- **.080 State Plumbers Examining Committee.**
- **.090 Inspectors -- Appointment -- Qualifications.**
- **.100 Advertising by licensee.**
- **.110 Company or individual connected with licensed plumber may engage in plumbing business -- Notice of connection.**
- **.120 Employment of unlicensed plumber prohibited.**
- **.130 Kentucky State Plumbing Code -- Administrative regulations.**
- **.134 Installation permits -- Requisites -- Fees.**
- **.136 Trust and agency fund.**
- **.140 Adoption and enforcement of State Plumbing Code by local governments -- Local inspectors -- Qualifications.**
- **.150 Materials and methods to be used.**
- **.160 Installation plans and specifications.**
- **.165 Requisites for providing permanent water supply.**
- **.170 Authority of agents of department.**
- **.180 Enforcement of plumbing laws.**
- **.190 Jurisdiction for enforcement actions.**
- **.200 Water heating devices -- Serial numbers.**
- **.990 Penalties.**

318.010 Definitions for chapter.

As used in this chapter, unless the context requires otherwise:

- (1) "**Department**" means Department of Housing, Buildings and Construction;
- (2) "**Journeyman plumber**" means a person who engages or offers to engage, either as an occupation or otherwise, in the construction, installation, alteration, maintenance, repair, remodeling or removal, and replacement of plumbing under the supervision, direction, and responsibility of a master plumber;
- (3) "**Master plumber**" means a person who assumes responsible charge, supervision, or direction of journeyman plumbers, plumbers' apprentices, and other persons in the construction, installation, or alteration of plumbing or who engages in, offers to engage in, or advertises or otherwise represents that he is permitted or qualified to engage in the design, planning, superintending, contracting for, or responsible charge of plumbing;
- (4) "**Plumbing**" means the art of installing in buildings the pipes for distributing the water supply, the fixtures for using water and drainage pipes for removing waste water and sewage, together with fittings, appurtenances, and appliances of various kinds, all within or adjacent to the building. It shall not include the installation of on-site sewage disposal systems, except for the piping, fixtures, or other appurtenances needed within the building. It shall include:
 - (a) The water service pipe which forms the connection between the property line and the building, other than piping serving firefighting equipment;
 - (b) Private water supply systems;
 - (c) House sewers which convey the waste water and sewage from the building to the property line or other points of disposal, but not including sewers located between manholes and sewers extending five (5) feet from a main or manhole on private property;
 - (d) Storm sewers and rain water piping located within a building to a point two (2) feet outside of the building; and
 - (e) Medical gas piping;
- (5) "**Public building**" means any building intended for public use or built with public funds and includes but is not limited to the following: schools, industrial establishments, housing projects, restaurants, food-handling establishments, private clubs, theaters including drive-ins, trailer coach parks, camping areas, hospitals, nursing homes, hotels, motels, tourist courts, rooming houses, boarding houses, and other establishments furnishing public sleeping accommodations;
- (6) "**Maintenance man**" means a person employed to maintain and keep plumbing in good repair;
- (7) "**Apprentice**" means a person in the process of learning the plumbing trade who assists and is under the personal supervision of a licensed master or licensed journeyman plumber;
- (8) "**Farmstead**" means a farm dwelling together with other farm buildings and structures incident to the operation and maintenance of the farm situated on ten (10) acres or more of land which is located outside the corporate limits of a municipality;
- (9) "**Person**" means any individual, public or private corporation, political subdivision, government agency, municipality, co-partnership, association, firm, trust, estate, or other entity whatsoever;
- (10) "**Commissioner**" means the commissioner of the Department of Housing, Buildings and Construction; and
- (11) "**Code**" means the Kentucky State Plumbing Code.

Effective: July 15, 2010

History: Amended 2010 Ky. Acts ch. 24, sec. 1670, effective July 15, 2010. -- Amended 1996 Ky. Acts ch. 157, sec. 1, effective July 15, 1996. -- Amended 1986 Ky. Acts ch. 354, sec. 5, effective July 15, 1986. -- Amended 1982 Ky. Acts ch. 392, sec. 6, effective July 15, 1982. -- Amended 1978 Ky. Acts ch. 117, sec. 49, effective July 1, 1978; and ch. 155, sec. 149, effective June 17, 1978. -- Amended 1976 Ky. Acts ch. 193, sec. 1; and ch. 299, sec. 60. -- Amended 1974 Ky. Acts ch. 74, Art. VI, sec. 91. -- Amended 1970 Ky. Acts ch. 162, sec. 1. -- Amended 1960 Ky. Acts ch. 222, sec. 1, effective June 16, 1960. -- Recodified 1942 Ky. Acts ch. 208, sec. 1, effective October 1, 1942, from Ky. Stat. sec. 3909b.

318.015 Application of chapter and of state plumbing code.

- (1) This chapter shall apply to and shall be in full force and effect in all counties of the Commonwealth.
- (2) The state plumbing code promulgated by the department under the provisions of this chapter shall apply to and shall be in full force and effect for all public buildings regardless of location in the Commonwealth.
- (3) This chapter shall not apply to farmsteads.

Effective: June 29, 2017

History: Amended 2017 Ky. Acts ch. 169, sec. 102, effective June 29, 2017. -- Amended 2010 Ky. Acts ch. 24, sec. 1671, effective July 15, 2010. -- Amended 1976 Ky. Acts ch. 299, sec. 61. -- Amended 1974 Ky. Acts ch. 126, sec. 1. -- Amended 1968 Ky. Acts ch. 194, sec. 1. -- Created 1960 Ky. Acts ch. 222, sec.2.

318.020 Apprentices, maintenance men, water company or district employees exempt.

- (1) Nothing contained in this chapter shall be construed as prohibiting the employment of an apprentice to assist a journeyman plumber in his duties.
- (2) This chapter shall not apply to anyone who is employed or acts as a maintenance man.
- (3) This chapter shall not apply to persons employed by any water company, water district or sanitation district, in the laying, maintenance, and operation of its mains and other appurtenances in the conduct of its business.
- (4) The provisions of this chapter relating to the licensure of plumbers shall apply to all persons engaged in the practice of plumbing.

History: Amended 1974 Ky. Acts ch. 126, sec. 2. -- Amended 1968 Ky. Acts ch. 194, sec. 2. -- Amended 1960 Ky. Acts ch. 222, sec. 3. -- Recodified 1942 Ky. Acts ch. 208, sec. 1, effective October 1, 1942, from Ky. Stat. sec. 3909b.

318.030 License and general liability insurance required.

- (1) No person shall engage in plumbing or engage in or work at the trade of plumbing:
 - (a) Unless he or she is the holder of a valid and effective active master plumber's license duly issued by the department in accordance with the provisions of this chapter; or
 - (b) Unless he or she is the holder of a valid and effective journeyman plumber's license duly issued by the department in accordance with the provisions of this chapter.
- (2)
 - (a) No person, firm, or corporation shall engage in plumbing or engage in or work at the trade of plumbing unless the person, firm, or corporation maintains general liability insurance in an amount not less than two hundred fifty thousand dollars (\$250,000) and submits proof of compliance with workers' compensation and unemployment insurance laws of the Commonwealth.
 - (b) Proof of insurance required in this subsection shall be submitted to the department prior to issuance or renewal of the active master plumber license required under this chapter.
 - (c) No license shall be valid without insurance as required in this subsection, and insurance carriers shall notify the department upon cancellation of the insurance of any licensee required to maintain insurance.
 - (d) The insurance required in this subsection shall not apply to an employee of a person, firm, or corporation engaged in plumbing as defined in this chapter.

Effective: July 15, 2010

History: Amended 2010 Ky. Acts ch. 24, sec. 1672, effective July 15, 2010. -- Amended 2004 Ky. Acts ch. 40, sec. 1, effective July 13, 2004. -- Amended 1974 Ky. Acts ch. 126, sec. 3. -- Amended 1968 Ky. Acts ch. 194, sec. 3. -- Amended 1960 Ky. Acts ch. 222, sec. 4. -- Recodified 1942 Ky. Acts ch. 208, sec. 1, effective October 1, 1942, from Ky. Stat. sec. 3909b.

318.040 Qualifications -- Examinations -- Reciprocity.

- (1) An applicant for a master or journeyman plumber's license shall:
 - (a) Be at least eighteen (18) years of age;
 - (b) Be of good moral character;
 - (c) Be a citizen of the United States or be a resident alien who is authorized to work in the United States; and
 - (d) Possess all the other qualifications that may be prescribed by administrative regulations of the commissioner.
- (2) Except as otherwise provided in this chapter, no master or journeyman plumber's license shall be issued except upon a successful passage of an examination as prescribed by the department.
- (3) Examinations for a license as a master plumber or journeyman plumber shall be conducted at times and places fixed by the regulations of the commissioner. Applicants for an examination shall furnish the information required by the commissioner and shall receive from the department due notice of the time and place of the examination.
- (4) The department shall prepare or cause to be prepared under its supervision examinations consisting of written and practical tests with such questions and tests by which the department will determine:
 - (a) With respect to master plumber's license applicants, that applicants are qualified in view of the definitions, provisions, and purposes of this chapter to carry on responsibly, reasonably, and competently, the activities which a licensed master plumber is authorized to engage in by this chapter; and
 - (b) With respect to journeyman plumber's license applicants, their knowledge and competency to carry on the activities which a licensed journeyman plumber is authorized to engage in by this chapter.
- (5) The examination papers shall be preserved by the department for a period of one (1) year.
- (6) The department may issue a license to any person who holds a valid license in another state if that state has a statewide plumbing code, the other state's examination is at least equal to that of Kentucky, and the other state agrees to reciprocate with Kentucky.

Effective: June 29, 2017

History: Amended 2017 Ky. Acts ch. 169, sec. 103, effective June 29, 2017. --Amended 2010 Ky. Acts ch. 24, sec. 1673, effective July 15, 2010. -- Amended 1994 Ky. Acts ch. 202, sec. 1, effective July 15, 1994. -- Amended 1990 Ky. Acts ch. 45, sec. 1, effective July 13, 1990. -- Amended 1978 Ky. Acts ch. 117, sec. 50, effective July 1, 1978. -- Amended 1974 Ky. Acts ch. 74, Art. VI, sec. 107(22). -- Amended 1960 Ky. Acts ch. 222, sec. 5, effective June 16, 1960. --Recodified 1942 Ky. Acts ch. 208, sec. 1, effective October 1, 1942, from Ky.Stat. sec. 3909b-4.

318.050 Fees.

Each application for a license as a master or journeyman plumber shall be accompanied by a reasonable fee as established by the department in an administrative regulation promulgated in accordance with KRS Chapter 13A.

Effective: June 29, 2017

History: Amended 2017 Ky. Acts ch. 169, sec. 104, effective June 29, 2017. --Amended 2010 Ky. Acts ch. 24, sec. 1674, effective July 15, 2010. -- Amended 1976 Ky. Acts ch. 193, sec. 2. -- Amended 1960 Ky. Acts ch. 222, sec. 6, effective June 16, 1960. -- Recodified 1942 Ky. Acts ch. 208, sec. 1, effective October 1, 1942, from Ky. Stat. sec. 3909b-1.

318.054 License expiration -- Notice -- Renewal and revival fees -- Evidence of completion of continuing education -- Interim period for use of recently deceased owner's or employee's master plumber's license.

(1) The initial license for a master or journeyman plumber shall expire on the last day of the licensee's birth month in the following year. The department may reduce the license fee on a pro rata basis for initial licenses issued for less than twelve (12) months. Renewed licenses shall expire on the last day of the licensee's birth month of each year after the date of issuance of the renewed license.

(2) The department shall require an applicant for renewal of a license to show evidence of completing the continuing education requirements established by the department in administrative regulations promulgated under KRS 318.130.

(3) The department shall send each licensed master and journeyman plumber a notice advising them that the annual license renewal fee is due. The notice shall be sent to the licensee's last known address no later than thirty (30) days prior to the expiration of the license. The annual license renewal fee shall be a reasonable fee set by regulation of the department. The fee for the renewal of a master plumber's license shall exceed the fee charged for a journeyman plumber's license.

(4) A master or journeyman plumber who fails to renew a license prior to expiration may have the license renewed upon payment of the required renewal fee, a revival fee, and upon showing the completion of continuing education requirements. The revival fee for a master plumber shall be five dollars (\$5) and for a journeyman plumber three dollars (\$3). If the renewal and revival fees are not paid within one hundred eighty (180) days after the license expires, the license shall be automatically canceled by operation of law for nonpayment. A license may be reinstated upon payment of all delinquent renewal fees plus a revival fee of ten dollars (\$10) for a master plumber and six dollars (\$6) for a journeyman plumber. Upon presentation of proper evidence, the department may waive payment of any renewal or revival fee for a person serving on active duty in the Armed Forces of the United States.

(5) (a) The department shall grant an interim period of up to one hundred eighty (180) continuous calendar days to allow a company to utilize the master plumber's license of a recently deceased owner or deceased employee who procured plumbing permits for that company, provided that the company:

1. Effectuates and documents all necessary bonding and insurance policies required in this chapter; and
2. Ensures that the bonding and insurance policies remain in effect for the entirety of the interim time period extended by the department.

(b) The license of a deceased master plumber shall be terminated by the department at the end of the interim period.

(c) Upon termination of the deceased master plumber's license, a company shall have an employee with a current and valid Kentucky master plumber's license in order to procure permits and perform plumbing work governed by this chapter.

Effective: July 14, 2018

History: Amended 2018 Ky. Acts ch. 22, sec. 5, effective July 14, 2018. -- Amended 2017 Ky. Acts ch. 169, sec. 105, effective June 29, 2017. -- Amended 2010 Ky. Acts ch. 24, sec. 1675, effective July 15, 2010. -- Amended 2006 Ky. Acts ch. 167, sec. 2, effective July 1, 2007. -- Amended 2005 Ky. Acts ch. 182, sec. 3, effective June 20, 2005. -- Amended 1976 Ky. Acts ch. 299, sec. 62. -- Created 1960 Ky. Acts ch. 222, sec. 7, effective June 16, 1960.

318.060 Reexamination.

An applicant who fails an examination shall be eligible to take the next regular examination upon submitting a new application and paying an additional application fee. Applications shall be canceled one (1) year after receipt thereof if the applicant fails to appear for examination.

Effective: June 29, 2017 **History:** Amended 2017 Ky. Acts ch. 169, sec. 106, effective June 29, 2017. -- Amended 1960 Ky. Acts ch. 222, sec. 9, effective June 16, 1960. -- Recodified 1942 Ky. Acts ch. 208, sec. 1, effective October 1, 1942, from Ky. Stat. sec. 3909b-1

318.064 Revocation or suspension of license.

The department may revoke or suspend any plumber's license upon proof that the licensee:

- (1) Has knowingly violated this chapter, the Kentucky State Plumbing Code, or the rules and regulations of the department;
- (2) Has practiced fraud or deception in applying for or obtaining a license;
- (3) Is incompetent to perform services as a licensed master plumber or a licensed journeyman plumber;
- (4) Has permitted his or her license to be used directly or indirectly by another to obtain or perform plumbing work or services; or
- (5) Is guilty of other unprofessional or dishonorable conduct of a character likely to deceive or defraud the public.

Effective: June 29, 2017

History: Amended 2017 Ky. Acts ch. 169, sec. 107, effective June 29, 2017. -- Amended 2010 Ky. Acts ch. 24, sec. 1676, effective July 15, 2010. -- Amended 1976 Ky. Acts ch. 299, sec. 63. -- Created 1960 Ky. Acts ch. 222, sec. 10, effective June 16, 1960.

318.066 Hearing -- Appeal.

- (1) A license shall not be suspended or revoked by the department unless a hearing has been conducted or an opportunity afforded therefor in accordance with KRS Chapter 13B.
- (2) A licensee aggrieved by a final order of the department suspending or revoking a license may appeal to the Circuit Court of the county in which the appellant's principal office is located in accordance with KRS Chapter 13B.

Effective: June 29, 2017

History: Amended 2017 Ky. Acts ch. 169, sec. 108, effective June 29, 2017. -- Amended 2010 Ky. Acts ch. 24, sec. 1677, effective July 15, 2010. -- Amended 1996 Ky. Acts ch. 318, sec. 274, effective July 15, 1996. -- Amended 1980 Ky. Acts ch. 114, sec. 77, effective July 15, 1980. -- Amended 1978 Ky. Acts ch. 117, sec. 51, effective July 1, 1978. -- Amended 1976 Ky. Acts ch. 299, sec. 64. -- Amended 1974 Ky. Acts ch. 315, sec. 56. -- Amended 1966 Ky. Acts ch. 255, sec. 249. -- Created 1960 Ky. Acts ch. 222, sec. 11.

318.077 Review and comment on amendments to code -- Appeals.

- (1) No amendment of the code or any other related administrative regulation shall be promulgated by the department without the prior review and comment of the Housing, Buildings and Construction Advisory Committee under the requirements of KRS 198B.030(8).
- (2) Any person aggrieved by any administrative regulation or amendment thereto promulgated by the department, within thirty (30) days after the action has become final, may appeal to the Circuit Court. For the purposes of this subsection, "persons aggrieved" shall include any person directly or indirectly injured or threatened with injury on account of any administrative regulation or amendment thereto promulgated by the department, whether or not that person was a party to the proceedings out of which the order administrative regulation, or amendment arose.

Effective: June 29, 2017

History: Amended 2017 Ky. Acts ch. 169, sec. 109, effective June 29, 2017. -- Amended 2011 Ky. Acts ch. 100, sec. 20, effective June 8, 2011. -- Amended 2010 Ky. Acts ch. 24, sec. 1680, effective July 15, 2010. -- Amended 2006 Ky. Acts ch. 256, sec. 9, effective July 12, 2006. -- Amended 1978 Ky. Acts ch. 117, sec. 54, effective July 1, 1978; and ch. 155, sec. 152, effective June 17, 1978. -- Amended 1976 Ky. Acts ch. 193, sec. 4; and ch. 299, sec. 67. -- Created 1966 Ky. Acts ch. 79, sec. 6.

318.080 State Plumbers Examining Committee.

(1) In order to conduct examinations for persons to qualify as licensed master plumbers or journeyman plumbers, the department shall appoint as examiners the following persons to a State Plumbers Examining Committee: An employee of the department and three (3) other persons who shall be licensed either as master or journeyman plumbers. The commissioner shall be an ex officio examiner and permanent commissioner of the examining committee. With the exception of the issuance of any order involving the revocation, suspension or cancellation of a master or journeyman plumber's license, the commissioner may delegate to a subordinate employee in the department the power to be present and participate, including the right to vote, as his or her representative at any meeting, hearing or other proceeding of the State Plumbers Examining Committee. Plumber examiners shall serve at the pleasure of the department.

(2) The department shall appoint assistant plumber examiners who are qualified licensed master or journeyman plumbers, who shall serve at the pleasure of the department. Assistant plumber examiners shall perform duties as are delegated to them by the State Plumbers Examining Committee.

(3) Plumber examiners and assistant plumber examiners shall receive no compensation for their services, but shall be reimbursed for their necessary traveling expenses.

Effective: June 29, 2017

History: Amended 2017 Ky. Acts ch. 169, sec. 110, effective June 29, 2017. -- Amended 2010 Ky. Acts ch. 24, sec. 1681, effective July 15, 2010. -- Amended 1978 Ky. Acts ch. 117, sec. 55, effective July 1, 1978; and ch. 155, sec. 153, effective June 17, 1978. -- Amended 1976 Ky. Acts ch. 299, sec. 68. -- Amended 1974 Ky. Acts ch. 74, Art. VI, sec. 92. -- Amended 1970 Ky. Acts ch. 92, sec. 87. -- Amended 1960 Ky. Acts ch. 222, sec. 12, effective June 16, 1960. -- Recodified 1942 Ky. Acts ch. 208, sec. 1, effective October 1, 1942, from Ky. Stat. sec. 3909b-1.

318.090 Inspectors -- Appointment -- Qualifications.

(1) The department shall appoint and assign plumbing inspectors to each county subject to the provisions of this chapter.

(2) Each plumbing inspector shall have at least eight (8) years experience as a journeyman or master plumber. At the time of his or her appointment he or she shall be licensed in accordance with the provisions of this chapter.

Effective: July 15, 2010

History: Amended 2010 Ky. Acts ch. 24, sec. 1682, effective July 15, 2010. -- Amended 1974 Ky. Acts ch. 126, sec. 5. -- Amended 1968 Ky. Acts ch. 194, sec. 5. -- Amended 1960 Ky. Acts ch. 222, sec. 13. -- Recodified 1942 Ky. Acts ch. 208, sec. 1, effective October 1, 1942, from Ky. Stat. sec. 3909b-9.

318.100 Advertising by licensee.

No person shall advertise as or claim to be a licensed master or licensed journeyman plumber within the Commonwealth of Kentucky unless that person holds a master or journeyman plumber license from the department in accordance with this chapter.

Effective: June 29, 2017

History: Amended 2017 Ky. Acts ch. 169, sec. 111, effective June 29, 2017. -- Amended 2010 Ky. Acts ch. 24, sec. 1683, effective July 15, 2010. -- Amended 1976 Ky. Acts ch. 299, sec. 69. -- Amended 1974 Ky. Acts ch. 126, sec. 6. -- Amended 1960 Ky. Acts ch. 222, sec. 14, effective June 16, 1960. -- Recodified 1942 Ky. Acts ch. 208, sec. 1, effective October 1, 1942, from Ky. Stat. sec. 3909b-5.

318.110 Company or individual connected with licensed plumber may engage in plumbing business -- Notice of connection.

A company or individual principal may engage in the business of plumbing within any county of the Commonwealth if a person connected with that company or individual principal in responsible charge of the plumbing work is a licensed master plumber. Any master plumber, in responsible charge of plumbing work for a

company or individual engaged in the plumbing business, shall notify the department at any time he or she commences or severs his or her connection with the company or individual principal.

Effective: June 29, 2017

History: Amended 2017 Ky. Acts ch. 169, sec. 112, effective June 29, 2017. -- Amended 2010 Ky. Acts ch. 24, sec. 1684, effective July 15, 2010. -- Amended 1978 Ky. Acts ch. 384, sec. 106, effective June 17, 1978. -- Amended 1968 Ky. Acts ch. 194, sec. 6. -- Amended 1960 Ky. Acts ch. 222, sec. 15. -- Recodified 1942 Ky. Acts ch. 208, sec. 1, effective October 1, 1942, from Ky. Stat. sec. 3909b-7.

318.120 Employment of unlicensed plumber prohibited.

No person or corporation who assumes responsible charge and direction of other persons in the installation of plumbing shall employ or engage any person not licensed under this chapter to perform and install plumbing. Provided, however, that this section shall not be deemed to prohibit the employment or use of an apprentice as defined in this chapter.

History: Amended 1974 Ky. Acts ch. 126, sec. 7. -- Amended 1968 Ky. Acts ch. 194, sec. 7. -- Amended 1960 Ky. Acts ch. 222, sec. 16. -- Recodified 1942 Ky. Acts ch. 208, sec. 1, effective October 1, 1942, from Ky. Stat. sec. 3909b

318.130 Kentucky State Plumbing Code -- Administrative regulations.

In order to administer this chapter, the department shall promulgate and thereafter from time to time may amend a code to be known as the Kentucky State Plumbing Code, regulating the construction, installation, and alteration of plumbing and plumbing fixtures and appliances, house sewers and private water supplies, and methods and materials to be used therein within this state, using as a minimum standard the basic principles of the National Plumbing Code Coordinating Committee, as evidenced by that committee's final report of 1951 with variations thereof or additions thereto as the committee considers are warranted by local, climatic, or other conditions. The code may also designate the number of plumbing fixtures for public buildings. The department may adopt any other reasonable

administrative regulation to administer this chapter if the administrative regulation has been subject to review and comment by the Housing, Buildings and Construction Advisory Committee under the requirements of KRS 198B.030(8). No rules or regulations so approved by the Housing, Buildings and Construction Advisory Committee shall become effective except upon adoption by the department, in satisfaction of the requirements of KRS Chapter 13A. The department shall furnish to the Housing, Buildings and Construction Advisory Committee proposed amendments to the code for the committee's review and comment prior to their adoption by the department. The department shall not promulgate any administrative regulations related to this chapter without granting the Housing, Buildings and Construction Advisory Committee the opportunity to comment on the administrative regulation.

Effective: June 29, 2017

History: Amended 2017 Ky. Acts ch. 169, sec. 113, effective June 29, 2017. -- Amended 2011 Ky. Acts ch. 100, sec. 21, effective June 8, 2011. -- Amended 2010 Ky. Acts ch. 24, sec. 1685, effective July 15, 2010. -- Amended 2006 Ky. Acts ch. 256, sec. 10, effective July 12, 2006. -- Amended 1982 Ky. Acts ch. 392, sec. 7, effective July 15, 1982. -- Amended 1976 Ky. Acts ch. 193, sec. 5; and ch. 299, sec. 70. -- Amended 1968 Ky. Acts ch. 152, sec. 147. -- Amended 1966 Ky. Acts ch. 79, sec. 1. -- Amended 1960 Ky. Acts ch. 222, sec. 17. -- Recodified 1942 Ky. Acts ch. 208, sec. 1, effective October 1, 1942, from Ky. Stat. sec. 3909b-2.

Legislative Research Commission Note (10/5/90). Pursuant to KRS 7.136(1), KRS Chapter 13A has been substituted for the prior reference to KRS Chapter 13 in this statute. The sections in KRS Chapter 13 were repealed by 1984 Ky. Acts ch. 417, 36 and KRS Chapter 13A was created in that same chapter of the 1984 Ky. Acts

318.134 Installation permits -- Requisites -- Fees.

(1) No person, firm, or corporation shall:

(a) Construct, install, or alter, or cause to be constructed, installed, or altered, any plumbing without first having procured a plumbing installation permit therefor from the department;

(b) Use or continue to use, or permit the use or continued use of, any plumbing constructed, installed, or altered under a plumbing installation permit issued therefor where the department through a duly authorized inspector, employee, or agent, finds that the plumbing was not constructed, installed, or altered in accordance with such permit and the Kentucky State Plumbing Code.

(2) All applications for plumbing installation permits shall be accompanied by plans and specifications of the proposed plumbing installation, location, and construction of the water supply system to be used. If an on-site sewage disposal system that does not have a surface discharge is proposed, a valid on-site sewage disposal permit issued by the Cabinet for Health and Family Services or its designated agent shall accompany the application.

(3) The department shall fix a reasonable schedule of fees and charges to be paid for plumbing installation permits and the necessary inspections incident thereto. The department shall also fix a reasonable schedule of fees and charges to be paid for necessary inspections of the construction, installation, or alteration of plumbing in public buildings.

Effective: July 15, 2010

History: Amended 2010 Ky. Acts ch. 24, sec. 1686, effective July 15, 2010. -- Amended 2005 Ky. Acts ch. 99, sec. 600, effective June 20, 2005. -- Amended 1998 Ky. Acts ch. 426, sec. 551, effective July 15, 1998. -- Amended 1982 Ky. Acts ch. 392, sec. 8, effective July 15, 1982. -- Amended 1978 Ky. Acts ch. 244, sec. 2, effective June 17, 1978. -- Amended 1976 Ky. Acts ch. 299, sec. 71. -- Amended 1974 Ky. Acts ch. 126, sec. 8. -- Amended 1968 Ky. Acts ch. 194, sec. 8. -- Created 1960 Ky. Acts ch. 222, sec. 18.

318.136 Trust and agency fund.

All license fees, permit and inspection fees and charges, and other moneys collected by the department, under the provisions of this chapter and the rules and regulations of the department adopted hereunder, shall be paid into the State Treasury and credited to a trust and agency fund to be used by the department in carrying out the provisions of this chapter. No part of this fund shall revert to the general fund of the Commonwealth. All moneys held in a trust and agency fund or other fund to the credit of the department for the administration and enforcement of this chapter on June 16, 1960, are hereby transferred to the trust and agency fund herein created.

Effective: July 15, 2010

History: Amended 2010 Ky. Acts ch. 24, sec. 1687, effective July 15, 2010. -- Amended 1976 Ky. Acts ch. 299, sec. 72. -- Created 1960 Ky. Acts ch. 222, sec. 19, effective June 16, 1960.

318.140 Adoption and enforcement of State Plumbing Code by local governments -- Local inspectors -- Qualifications.

(1) Any local government may, by ordinance, enact the Kentucky State Plumbing Code, regulating the construction, installation, or alteration of plumbing within such local government, providing for the issuance of plumbing installation permits and fixing permit and inspection fees. Two (2) or more local governments may, by ordinance of each local government, enact the plumbing code as described in this section which shall be jointly enforced and administered by said local governments within their boundaries. Agreements for joint enforcement shall conform to the provisions of KRS Chapter 65. The department may authorize any such local government or combination of local governments to administer, carry out, and enforce the Kentucky State Plumbing Code and the rules and regulations of the department relating thereto and to issue permits and make inspections thereunder within such local government, in which event a permit issued under the provisions of the local government plumbing code ordinance shall be deemed a permit issued by the department; provided, however, that inspectors of the department shall have concurrent jurisdiction with local government plumbing inspectors in the enforcement in such local governments of the Kentucky State Plumbing Code.

(2) Any local government enacting a plumbing code ordinance may appoint and fix the compensation of local government plumbing inspectors. No person shall be eligible for appointment as a local government plumbing inspector unless he or she has at least eight (8) years' experience as a master or journeyman plumber. At the time of his or her appointment, he or she shall be licensed in accordance with the provisions of this chapter.

(3) Nothing contained in this chapter shall be construed as prohibiting a local government from collecting occupational license fees from persons, firms, or corporations engaged in the plumbing business.

Effective: July 15, 2010

History: Amended 2010 Ky. Acts ch. 24, sec. 1688, effective July 15, 2010. -- Amended 1978 Ky. Acts ch. 117, sec. 56, effective July 1, 1978. -- Amended 1976 Ky. Acts ch. 299, sec. 73. -- Amended 1960 Ky. Acts ch. 222, sec. 20, effective June 16, 1960. -- Recodified 1942 Ky. Acts ch. 208, sec. 1, effective October 1, 1942, from Ky. Stat. sec. 3909b-8.

318.150 Materials and methods to be used.

No person shall use unsafe or defective material in the work of plumbing or drainage. Only the best known methods of installing materials, fixtures, appurtenances and appliances, including water supply piping, waste, ventilating and soil piping, and sewage piping shall be employed.

Effective: June 16, 1960

History: Amended 1960 Ky. Acts ch. 222, sec. 21, effective June 16, 1960. -- Recodified 1942 Ky. Acts ch. 208, sec. 1, effective October 1, 1942, from Ky. Stat. sec. 3909b-3..

318.160 Installation plans and specifications.

Except as otherwise provided by law or by regulation of the department, no person shall construct, install, or extensively alter any plumbing, sewerage, or water supply system of any public building or establishment without having first obtained the approval of the department in writing. Detailed plans and specifications of the proposed facility showing the plumbing system, sewage disposal system, and water supply system shall be submitted to the department prior to the construction or alteration of the facility. In the event no public sewer is available, the plan shall include the proposed type of sewage disposal system. In the event a sewage subsoil drainage system is used, or some other type of on-site sewage disposal system that does not have a surface discharge, the application for construction, installation, or alteration of such system shall be submitted to the Cabinet for Health and Family Services or its designated agent. All other plans and specifications shall be submitted in triplicate to the department. The department shall notify the applicant in writing of the approval or disapproval of the plans. The construction, installation, or alteration shall be done in accordance with the approved plans.

Effective: July 15, 2010

History: Amended 2010 Ky. Acts ch. 24, sec. 1689, effective July 15, 2010. -- Amended 2005 Ky. Acts ch. 99, sec. 601, effective June 20, 2005. -- Amended 1998 Ky. Acts ch. 426, sec. 552, effective July 15, 1998. -- Amended 1982 Ky. Acts ch. 392, sec. 9, effective July 15, 1982. -- Amended 1978 Ky. Acts ch. 244, sec. 3, effective June 17, 1978. -- Amended 1976 Ky. Acts ch. 299, sec. 74. -- Created 1960 Ky. Acts ch. 222, sec. 22, effective June 16, 1960.

318.165 Requisites for providing permanent water supply.

No permanent water supply shall be provided to any building by any public utility or water district where the interior plumbing system has not been installed and approved in accordance with the provisions of KRS Chapter 318 and the State Plumbing Code.

History: Created 1974 Ky. Acts ch. 126, sec. 9. ch. 126, sec. 9.

318.170 Authority of agents of department.

For the purpose of enforcing the provisions of this chapter and the State Plumbing Code, officers, agents, and inspectors of the department shall have the power and authority to enter upon premises at all reasonable times for the purpose of making inspections, to interrogate all persons and to require the production of plumbing installation permits and other evidence. Officers, agents, and inspectors of the department are empowered to issue a stop order to any owner, agent, or occupant of real property whenever the plumbing thereon is found by the officer, agent or inspector of the department to be in violation of this chapter or the State Plumbing Code.

Effective: July 15, 2010

History: Amended 2010 Ky. Acts ch. 24, sec. 1690, effective July 15, 2010. -- Created 1960 Ky. Acts ch. 222, sec. 23, effective June 16, 1960.

318.180 Enforcement of plumbing laws.

(1) Notwithstanding the existence or pursuit of any other remedy (civil or criminal) the department, or its officers, agents, or inspectors, are hereby authorized to institute and maintain actions to restrain and enjoin any violation of this chapter, the State Plumbing Code, or the rules and regulations of the department relating thereto.

(2) City, county and Commonwealth's attorneys, and the Attorney General, shall within their respective jurisdictions represent the department, its officers, agents, and inspectors, in the enforcement of the provisions of this chapter, the State Plumbing Code, and the rules and regulations of the department relating thereto, but when the department deems it necessary, it may employ, at its discretion, special attorneys to assist the department, or its officers, agents, or inspectors, and may pay reasonable compensation, fees and other costs from any unexpended plumbing funds.

Effective: July 15, 2010

History: Amended 2010 Ky. Acts ch. 24, sec. 1691, effective July 15, 2010. -- Amended 1976 Ky. Acts ch. 299, sec. 75. -- Created 1960 Ky. Acts ch. 222, sec. 24, effective June 16, 1960.

318.190 Jurisdiction for enforcement actions.

(1) The Circuit Court where the violation occurs shall have jurisdiction and venue in all civil and injunctive actions instituted by the department for the enforcement of the provisions of KRS Chapter 318 and the State Plumbing Code and the orders issued thereunder.

(2) The Franklin Circuit Court shall hold concurrent jurisdiction and venue in all civil and injunctive actions instituted by the department, or upon the secretary's request by the Attorney General, for the enforcement of the provisions of KRS Chapter 318, the State Plumbing Code and the orders issued thereunder and other rules and regulations of the department.

(3) The District Court where the violation occurs shall have jurisdiction and venue in all criminal actions for the enforcement of the provisions of KRS Chapter 318 and the State Plumbing Code and the orders issued thereunder. The Franklin Circuit Court shall hold concurrent jurisdiction and venue on all appeals of criminal actions for the enforcement of the provisions of KRS Chapter 318 and the State Plumbing Code and the orders issued thereunder.

Effective: July 15, 2010

History: Amended 2010 Ky. Acts ch. 24, sec. 1692, effective July 15, 2010. -- Amended 1984 Ky. Acts ch. 45, sec. 1, effective July 13, 1984. -- Amended 1976 Ky. Acts ch. 193, sec. 6; and ch. 299, sec. 76. -- Created 1974 Ky. Acts ch. 126, sec. 10.

318.200 Water heating devices -- Serial numbers.

(1) No water heating device shall be sold or offered for sale in the Commonwealth of Kentucky unless it contains a serial number on it. As used in this section, "water heating device" means any pressure vessel which heats, stores, and supplies potable water for domestic or commercial purposes other than for space heating.

(2) All retailers, wholesalers, and installers selling or offering for sale a water heating device shall, within thirty (30) days of the date of sale, forward a list of names and addresses of purchasers along with the serial numbers of the devices purchased to the department or to the appropriate agency of county or city government having jurisdiction.

Effective: July 15, 2010

History: Amended 2010 Ky. Acts ch. 24, sec. 1693, effective July 15, 2010. -- Amended 1992 Ky. Acts ch. 5, sec. 1, effective July 14, 1992. -- Created 1984 Ky. Acts ch. 272, sec. 1, effective July 13, 1984.

318.990 Penalties.

Any person who violates any provision of this chapter or any regulation adopted hereunder or any provision of the State Plumbing Code shall be fined not less than ten dollars (\$10) nor more than one hundred dollars (\$100) or imprisoned for not more than ninety (90) days or both for each offense. Each day the violation continues shall constitute a separate offense.

Effective: June 16, 1960

History: Amended 1960 Ky. Acts ch. 222, sec. 25, effective June 16, 1960. -- Recodified 1942 Ky. Acts ch. 208, sec. 1, effective October 1, 1942, from Ky. Stat. sec. 3909b-10.

Basic Principles

Basic Principles

The department is directed by KRS 318.130 through the State Plumbing Code Committee to adopt and put into effect a State Plumbing Code. This code is founded upon certain basic principles or environmental sanitation and safety through properly designed acceptably installed and adequately maintained plumbing systems. Some of the details of plumbing construction may vary but the basic sanitary and safety principles desirable and necessary to protect the health of the people are the same everywhere. The establishment of trade jurisdictional areas is not within the scope of the code. The inclusion of a material even though indicated as approved for purposes of this code, does not infer unqualified endorsement as to its selection of serviceability in any or every installation. As interpretations may be required, and as unforeseen situations arise which are not specifically covered in this code, the Department has traditionally used and will continue to use the following twenty-two principles to define the intent

Principle No. 1. All occupied premises shall have potable water. All premises intended for human habitation, occupancy, or use shall be provided with a supply of potable water. Such a water supply shall not be connected with unsafe water sources, nor shall it be subject to the hazards of backflow or back-siphonage.

Principle No. 2. Adequate water required. Plumbing fixtures, devices, and appurtenances shall be supplied with water in sufficient volume and at pressures adequate to enable them to function properly and without undue noise under normal conditions of use.

Principle No. 3. Hot water required. Hot water shall be supplied to all plumbing fixtures which normally need or require hot water for their proper use and function.

Principle No. 4. Water conservation. Plumbing shall be designed and adjusted to use the minimum quantity of water consistent with proper performance and cleaning.

Principle No. 5. Safety devices. Devices for heating and storing water shall be so designed and installed as to guard against dangers from explosion or overheating,

Principle No. 6. Use public sewer where available. Every building with installed plumbing fixtures and intended for human habitation, occupancy, or use, and located on premises where public sewer is on or passes said premises within a reasonable distance shall be connected to the sewer

Principle No. 7. Required plumbing fixtures. Each family dwelling unit shall have at least one water closet, one lavatory, one kitchen-type sink, and one bathtub or shower to meet the basic requirements of sanitation and personal hygiene. All other structures for human habitation shall be equipped with sufficient sanitary facilities. Plumbing fixtures shall be made of durable, smooth, non-absorbent and corrosion resistant material and shall be free from concealed fouling surfaces.

Principle No. 8. Drainage system shall be designed, constructed and maintained to guard against fouling, deposit of solids and clogging, and with adequate cleanouts so arranged that the pipes may be readily cleaned.

Principle No. 9. Durable materials and good workmanship. The piping of the plumbing system shall be of durable material, free from defective workmanship and so designed and constructed as to give satisfactory service for its reasonable expected life.

Principle No. 10. Fixture traps. Each fixture directly connected to the drainage system shall be equipped with a liquid seal trap.

Principle No. 11. Trap seal shall be protected. The drainage system shall be designed to provide an adequate circulation of air in all pipes with no danger of siphonage, aspiration, or forcing of trap seals under conditions of ordinary use.

Principle No. 12. Exhaust of foul air to outside. Each vent terminal shall extend to the outer air and be so installed as to minimize the possibilities of clogging and the return of foul air to the building.

Principle No. 13. Test and plumbing system. The plumbing system shall be subjected to such tests as will effectively disclose all leaks and defects in the work or the material.

Principle No. 14. Exclude certain substances from the plumbing system. No substance which will clog or accentuate clogging of pipes, produce explosive mixtures, destroy the pipes or their joints, or interfere unduly with the sewage-disposal process shall be allowed to enter the building drainage system.

Principle No. 15. Prevent contamination. Proper protection shall be provided to prevent contamination of food, water, sterile goods, and similar materials by backflow of sewage. When necessary, the fixtures, device, or appliance shall be connected indirectly with the building drainage system.

Principle No. 16. Light and ventilation. No water closet or similar fixture shall be located in a room or compartment which is not properly lighted and ventilated.

Principle No. 17. Individual sewage disposal systems. If water closets or other plumbing fixtures are installed in buildings where there is no sewer within a reasonable distance, suitable provision shall be made for disposing of the sewage by some accepted method of sewage treatment and disposal.

Principle No. 18. Prevent sewer flooding. When a plumbing system is subject to backflow of sewage from the public sewer, suitable provision shall be made to prevent its overflow in the building.

Principle No. 19. Proper maintenance. Plumbing systems shall be maintained in a safe and serviceable condition from the stand point of both mechanics and health.

Principle No. 20. Fixtures shall be accessible. All plumbing fixtures shall be so installed with regard to spacing as to be accessible for their intended use and for cleaning.

Principle No. 21. Structural Safety. Plumbing shall be installed with due regard to preservation of the strength of structural members and prevention of damage to walls and other surfaces through fixture usage.

Principle No. 22. Protect ground and surface water. Sewage or other waste shall not be discharged into surface or sub-surface water unless it has first been subjected to some acceptable form of treatment.

Kentucky State Plumbing Code

815 KAR Chapter 20

- 010 Definitions for 815 KAR Chapter 20
- 020 Parts or materials list
- 030 Plumbing licenses
- 050 Installation permits
- 055 Water heating devices
- 060 Quality, weight, installation, and storage of materials
- 070 Plumbing fixtures
- 080 Waste pipe size
- 090 Soil, waste, vent systems, traps, and clean-outs
- 120 Water supply and distribution
- 130 House sewers and storm water piping; methods of installation
- 150 Inspection and tests
- 170 Manufactured home and mobile home community waste systems, water distribution, and connections
- 180 Special connections
- 191 Minimum fixture requirements
- 191reg Minimum fixture requirements
- 195 Medical gas piping installations

815 KAR 20:010. Definitions for 815 KAR Chapter 20.

RELATES TO: KRS 132.010, Chapter 318, 42 U.S.C. 300g-6

STATUTORY AUTHORITY: KRS 198B.040(10), 318.130

NECESSITY, FUNCTION, AND CONFORMITY: KRS 318.130 requires the department to promulgate an administrative regulation establishing the Kentucky State Plumbing Code to regulate plumbing. This administrative regulation establishes definitions for terms used in 815 KAR Chapter 20.

Section 1. Definitions. (1) "**ABS**" means acrylonitrile-butadiene styrene.

(2) "**Administrative authority**" means the Department of Housing, Buildings and Construction or any person or agency authorized by the department to administer and enforce the provisions of the Kentucky State Plumbing Code.

(3) "**Air break**" means a piping arrangement for a drainage system in which a drain from a fixture, appliance, or device discharges indirectly into another fixture, receptacle, or interceptor at a point below the flood level rim.

(4) "**Air gap**" means, for a drainage system, the unobstructed vertical distance through the free atmosphere between the outlet of waste pipe and the flood level rim of the receptacle into which it is discharging.

(5) "**Air gap**" means, for a water distribution system, the unobstructed vertical distance through the free atmosphere between the lowest opening from any pipe or faucet supplying water to a tank, plumbing fixture, or other device and the flood level rim of the receptacle.

(6) "**Anchors**" means "supports" as defined by this administrative regulation.

(7) "**ANSI**" means the American National Standards Institute.

(8) "**APML**" means the Approved Parts or Materials List as established in 815 KAR 20:020, Section 4.

(9) "**Apprentice**" is defined by KRS 318.010(7).

(10) "**Approved**" means accepted or acceptable under an applicable specification stated, established, or cited in this code.

(11) "**Area drain**" means a receptacle designed to collect surface or storm water from an open area.

(12) "**ASME**" means the American Society of Mechanical Engineers.

(13) "**Aspirator**" means a fitting or device supplied with water or other fluid under positive pressure, which passes through an integral orifice or constriction causing a vacuum. Aspirators are often referred to as suction apparatus and are similar in operation to an ejector.

(14) "**ASSE**" means the American Society of Sanitary Engineers.

(15) "**ASTM**" means the American Society for Testing and Materials.

(16) "**Autopsy table**" means a fixture or table used for postmortem examination of a body.

(17) "**Backflow**" means the flow of water or other liquids, mixtures, or substances into the distributing pipes of a potable supply of water from any source or sources other than its intended source. Back siphonage is one (1) type of backflow.

(18) "**Backflow connection**" means any arrangement whereby backflow could occur (see "cross connection" as defined by this administrative regulation).

(19) "**Backflow preventer**" means a device or means to prevent backflow.

(20) "**Backflow preventer, reduced pressure zone type**" means an assembly of differential valves and check valves, including an automatically opened spillage port to the atmosphere.

(21) "**Back siphonage**" means the flowing back of used, contaminated, or polluted water from a plumbing fixture or vessel or other sources into a potable water supply pipe due to a negative pressure in a pipe.

(22) "**Basement**" means the lowest level of a dwelling unit, which is wholly or partly below the ground level in which the entrance and exit is made by use of a stairway or other mechanical means and with or without an entrance and exit at the basement floor level.

(23) "**Basement floor drain**" means a drain placed in the basement floor of a residence that does or does not receive sanitary waste water.

(24) "**Battery of fixtures**" means any group of two (2) or more similar adjacent fixtures that discharge into a common horizontal waste or soil branch.

(25) "**Bedpan hopper**" means "clinical sink" as defined by this administrative regulation.

- (26) "**Bedpan steamer or boiler**" means a fixture used for scalding bedpans or urinals by direct application of steam of boiling water.
- (27) "**Bedpan unit**" means a small workroom in the nursing area designed and equipped for emptying, cleaning, and sometimes for steaming bedpans, and for no other purpose.
- (28) "**Bedpan washer and sterilizer**" means a fixture designed to wash bedpans and to flush the contents into the sanitary drainage system. It can also provide for disinfecting utensils by scalding with steam or hot water.
- (29) "**Bedpan washer hose**" means a device supplied with hot and cold water and located adjacent to a water closet or clinical sink to be used for cleaning bedpans.
- (30) "**Boiler blow-off**" means an outlet on a boiler to permit emptying or discharge of sediment.
- (31) "**Boiler blow-off tank**" means a vessel designed to receive the discharge from a boiler blow-off outlet and to cool the discharge to a temperature that permits its safe discharge to the drainage system.
- (32) "**Branch**" means that part of the piping system that extends horizontally, at a slight grade, with or without lateral or vertical extensions or vertical arms, from the main to receive fixture outlets not directly connected to the main.
- (33) "**Branch, fixture**" means "fixture branch" as defined by this administrative regulation.
- (34) "**Branch interval**" means a distance along a soil or waste stack corresponding in general to a story height, but in no case less than eight (8) feet, within which the horizontal branches from one (1) floor or story of a building are connected to the stack.
- (35) "**Branch vent**" means a vent connecting one (1) or more individual vents with a vent stack or stack vent.
- (36) "**Building**" means a structure having walls and a roof designed and used for the housing, shelter, enclosure, or support of persons, animals, or property.
- (37) "**Building classification**" means the arrangement of buildings in classes according to occupancy.
- (38) "**Building drain**" means that part of the lowest piping of a drainage system that receives the discharge from soil, waste, or other drainage pipes inside the walls of the building and conveys it to the building sewer beginning two (2) feet outside the building wall.
- (39) "**Building drain; combined**" means a building drain that conveys both sewage and storm water or other drainage.
- (40) "**Building drain; sanitary**" means a building drain that conveys sewage only.
- (41) "**Building drain; storm**" means a building drain that conveys storm water or other drainage but not sewage.
- (42) "**Building gravity drainage system**" means a drainage system that drains by gravity into the building sewer.
- (43) "**Building sewer**" means that part of the drainage system that extends from the end of the building drain and conveys its discharge to a public sewer, private sewer, individual sewage disposal system, or other point of disposal.
- (44) "**Building sewer; combined**" means a building sewer that conveys both sewage and storm water or other drainage.
- (45) "**Building sewer; sanitary**" means a building sewer that conveys sewage only.
- (46) "**Building sewer; storm**" means a building sewer that conveys storm water or other drainage but no sewage.
- (47) "**Building sub-drain**" means that portion of a drainage system that does not drain by gravity into the building sewer.
- (48) "**Cesspool**" means a lined and covered excavation in the ground that receives a discharge of domestic sewage or other organic wastes from a drainage system, so designed as to retain the organic matter and solids, but permitting the liquids to seep through the bottom and sides.
- (49) "**Circuit vent**" means a branch vent that serves two (2) or more traps and extends from the downstream side of the highest fixture connection of a horizontal branch to the vent stack.
- (50) "**CISPI**" means the Cast Iron Soil Pipe Institute.
- (51) "**Clinical sink**" or "bedpan hopper" means a fixture for the rinsing of bedpans and soiled linens.
- (52) "**Code**" is defined by KRS 318.010(11).

- (53) "**Combination fixture**" means a fixture combining one (1) sink and laundry tray or a two (2) or three (3) compartment sink or laundry tray in one (1) unit.
- (54) "**Combination waste and vent system**" means a specifically designed system of waste piping embodying the horizontal wet venting of one (1) or more sinks or floor drains by means of a common waste and vent pipe adequately sized to provide free movement of air above the free water surface in the drain.
- (55) "**Combined building drain**" means "building drain; combined" as defined by this administrative regulation.
- (56) "**Combined building sewer**" means "building sewer; combined" as defined by this administrative regulation.
- (57) "**Common vent**" means a vent connecting at the junction of two (2) fixture drains and serving as a vent for both fixture drains.
- (58) "**Conductor**" means a pipe inside the building that conveys storm water from the roof to a storm or combined building drain.
- (59) "**Continuous vent**" means a vertical vent that is a continuation of the drain to which it connects.
- (60) "**Continuous waste**" means a drain from two (2) or more fixtures connected to a single trap.
- (61) "**Cross connection**" means any physical connection or arrangement between two (2) otherwise separate piping systems, one (1) of which contains potable water and the other either water of unknown or questionable safety or steam, gas, or chemical whereby there could be a flow from one (1) system to the other, the direction of flow depending on the pressure differential between the two (2) systems. (See "backflow" and "back-siphonage" as defined by this administrative regulation.)
- (62) "**Critical level**" or "CL" means the level to which the vacuum breaker could be submerged before backflow will occur, and if the CL marking is not shown on the vacuum breaker, the bottom of the device is taken as the CL.
- (63) "**Dead end**" means a branch leading from a soil, waste or vent pipe, building drain, or building sewer, and terminating at a developed length of two (2) feet or more by means of a plug, cap, or other closed fitting.
- (64) "**Department**" means the Department of Housing, Buildings and Construction.
- (65) "**Developed length**" means the length of a pipe line measured along the center line of the pipe and fittings.
- (66) "**Developed travel distance**" means the length of a pathway measured along the center line of the path.
- (67) "**Diameter**" means the nominal diameter as designated commercially.
- (68) "**Division**" means the Division of Plumbing.
- (69) "**Domestic sewage**" means the waterborne wastes derived from ordinary living processes.
- (70) "**Double offset**" means two (2) changes of direction installed in succession or series in a continuous pipe.
- (71) "**Downspout**" means "**leader**" as defined by this administrative regulation.
- (72) "**Drain**" means any pipe that carries waste water or waterborne wastes in a building drainage system.
- (73) "**Drainage pipe**" means "**drainage system**" as defined by this administrative regulation.
- (74) "**Drainage system**":
- (a) Means all the piping, within public or private premises, which conveys sewage, rain water, or other liquid wastes to a point of disposal; and
 - (b) Does not mean:
 1. The mains of a public sewer system;
 2. A private or public sewage-treatment or disposal plant; or
 3. Plumbing appliances.
- (75) "**Drainage system**" means, for building gravity, a drainage system that drains by gravity into the building sewer.
- (76) "**Drainage system**" means, for a subbuilding, "building subdrain" as defined by this administrative regulation.
- (77) "**Dry well**" means "leaching well or pit" as defined by this administrative regulation.
- (78) "**Dual vent**" means "common vent" as defined by this administrative regulation.

- (79) "**Durham system**" means a soil or waste system in which all piping is of threaded pipe, tube, or other rigid construction, using recessed drainage fittings to correspond to the types of piping.
- (80) "**Dwelling unit**" means one (1) or more rooms with provision for living, sanitary, and sleeping facilities arranged for the use of one (1) family or individual.
- (81) "**DWV**" means drain, waste, and vent piping as used in common plumbing practice.
- (82) "**Effective opening**" means the minimum cross-sectional area at the point of water supply discharge, measured or expressed in terms of diameter of a circle, or if the opening is not circular, the diameter of a circle of equivalent cross-sectional area.
- (83) "**Ejector**" means "aspirator" as defined by this administrative regulation.
- (84) "**Existing work**" means a plumbing system or any part thereof installed prior to the effective date of the applicable provision of this code.
- (85) "**Farm**" as associated with "farmstead", as defined by KRS 318.010(8), means property with a bona fide "agricultural land" or "horticultural land" use as defined by KRS 132.010(9) and (10) and qualified by and registered with the PVA in that county.
- (86) "**Fire line**" means a system of pipes and equipment used exclusively to supply water for extinguishing fires.
- (87) "**Fixture**" means "plumbing fixture" as defined by this administrative regulation.
- (88) "**Fixture branch**" means the piping distance between a soil, waste, and vent stack and the fixture trap.
- (89) "**Fixture drain**" means the drain from the trap of a fixture to the junction of that drain with any other drain pipe.
- (90) "**Fixture supply**" means the water supply pipe connecting a fixture to a branch water supply pipe or directly to a main water supply pipe.
- (91) "**Fixture unit, drainage**" or "d.f.u." means a measure of the probable discharge into the drainage system by various types of plumbing fixtures. The drainage fixture-unit valve for a particular fixture depends on its volume rate of drainage discharge, on the time duration of a single drainage operation, and on the average time between successive operations. (Note: In general, on small systems, one (1) drainage fixture unit approximates one (1) cubic foot per minute.)
- (92) "**Fixture unit, supply**" or "s.f.u." means a measure of the probable hydraulic demand on the water supply by various types of plumbing fixtures. The supply fixture-unit valve for a particular fixture depends on its volume rate of supply, on the time duration of a single supply operation, and on the average time between successive operations.
- (93) "**Flood level**" means "flood level rim" as defined by this administrative regulation.
- (94) "**Flood level rim**" means the edge of the receptacle from which water overflows.
- (95) "**Flooded**" means the condition that results at the point the liquid in a container or receptacle rises to the flood-level rim.
- (96) "**Floor drain**" means a drain placed in the floor of a building for the purpose of receiving sanitary waste water.
- (97) "**Floor pantry**" means a workroom in the nursing area designed and equipped to prepare supplemental diets or beverages, and to assemble food trays at meal times if used in conjunction with decentralized food service.
- (98) "**Flow pressure**" means the pressure in the water supply pipe near the faucet or water outlet while the faucet or water outlet is wide-open and flowing.
- (99) "**Flush valve**" means a device located at the bottom of a tank for slushing water closets and similar fixtures.
- (100) "**Flushing type floor drain**" means a drain that is equipped with an integral water supply enabling flushing of the drain receptor and trap.
- (101) "**Flushometer valve**" means a device that discharges a predetermined quantity of water to fixtures for flushing purposes and is closed by direct water pressure.
- (102) "**Frost-proof closet**" means a hopper with no water in the bowl and with the trap and water supply control valve located below frost line.
- (103) "**Grade**" means the fall (slope) of a line of pipe in reference to a horizontal plane. In drainage it is usually expressed as the fall in a fraction of an inch per foot length of pipe.

- (104) "**Grade plane**" means a reference plane representing the average of finished ground level adjoining the building at exterior walls. If the finished ground level slopes away from the exterior walls, the reference plane is established by the lowest points within the area between the building and the lot line or, where the lot line is more than six (6) feet (1,829 mm) from the building, between the building and a point six (6) feet (1,829 mm) from the building.
- (105) "**Grease interceptor**" means "interceptor" as defined by this administrative regulation.
- (106) "**Grease trap**" means "interceptor" as defined by this administrative regulation.
- (107) "**Grillage**" means sand, pea gravel, or limestone rock sizes #57 and smaller used for bedding for piping systems.
- (108) "**Hangers**" means "supports" as defined by this administrative regulation.
- (109) "**Health care facility**" means a hospital, nursing home, limited care facility, clinic, ambulatory care center, or office practice medical or dental office.
- (110) "**Horizontal branch drain**" means a drain branch pipe extending laterally from a soil or waste stack or building drain, with or without vertical sections or branches, which receives the discharge from one (1) or more fixture drains and conducts it to the soil or waste stack or to the building drain.
- (111) "**Horizontal pipe**" means any pipe or fitting that makes an angle of less than forty-five (45) degrees with the horizontal.
- (112) "**Hose bibb**" means a sill cock, wall hydrant, or similar faucet with a downward angled threaded nozzle.
- (113) "**Hot water**" means water at a temperature of not less than 120 degrees Fahrenheit.
- (114) "**House drain**" means "building drain" as defined by this administrative regulation.
- (115) "**House sewer**" means "building sewer" as defined by this administrative regulation.
- (116) "**Indirect waste pipe**" means a waste pipe not directly connected with the drainage system, but that discharges into the drainage system through an air break or air gap into a trap, fixture, receptor, or interceptor.
- (117) "**Individual sewage disposal system**" means a system for disposal of domestic sewage by means of a septic tank, cesspool, or mechanical treatment, designed for use apart from a public sewer to serve a single establishment or building.
- (118) "**Individual vent**" means a pipe installed to vent a fixture drain. It connects with the vent system above the fixture served or terminates outside the building into the open air.
- (119) "**Individual water supply**" means a supply, other than an approved public water supply which serves one (1) or more families.
- (120) "**Industrial floor drain**" means a drain placed in the floor of a building other than in a toilet room or shower room to receive waste water.
- (121) "**Industrial wastes**" means liquid wastes resulting from the processes employed in industrial and commercial establishments.
- (122) "**Insanitary**" means contrary to sanitary principles and potentially injurious to health.
- (123) "**Interceptor**" means a device designed and installed so as to separate and retain deleterious, hazardous, or undesirable matter from normal wastes while permitting normal sewage or liquid wastes to discharge into the drainage system by gravity.
- (124) "**Installed**" means altered, changed, or a new installation.
- (125) "**Invert**" means the lowest portion of the inside of any horizontal pipe.
- (126) "**Kitchen sink unit**" means a sink, double or single compartment, food waste disposer, and dishwasher placed in a unit so arranged that the dishwasher abuts the sink.
- (127) "**Lavatory**" means a hand basin, such as in a bathroom.
- (128) "**Leaching well or pit**" means a pit or receptacle having porous walls that allow the contents to seep into the ground.
- (129) "**Lead**" means solders and flux containing more than two tenths (0.2) percent lead and the wetted surfaces of pipes, pipe fittings, plumbing fittings, and fixtures containing more than a weighted average of one fourth (0.25) percent lead as calculated according to the formula established in 42 U.S.C. 300g-6(d)(2).
- (130) "**Leader**" means an exterior drainage pipe for conveying storm water from roof or gutter drains.
- (131) "**Liquid waste**" means the discharge from any fixture, appliance, area or appurtenance, which does not contain fecal matter.

- (132) "**Load factor**" means the percentage of the total connected fixture unit flow that is likely to occur at any point in the drainage system.
- (133) "**Local vent stack**" means a vertical pipe to which connections are made from the fixture side of traps and through which vapor and foul air can be removed from the fixture or device used on bedpan washers.
- (134) "**Local ventilating pipe**" means a pipe through which foul air is removed from a room or fixture.
- (135) "**Loop vent**" means a circuit vent that loops back to connect with a stack vent instead of a vent stack.
- (136) "**Main**" means the horizontal, vertical, and continuous piping that receives the waste, soil, main, or individual vents from fixture outlets, or traps, directly or through branch pipes.
- (137) "**Main sewer**" means "public sewer" as defined by this administrative regulation.
- (138) "**Main vent**" means the principal artery of the venting system to which vent branches can be connected. (Manufacturer's Floor Drain. See "industrial floor drain" as defined by this administrative regulation.)
- (139) "**Medical gas system**" means an assembly of equipment and piping for the distribution of nonflammable medical gases such as oxygen, nitrous oxide, compressed air, carbon dioxide, and helium.
- (140) "**Medical-surgical vacuum system**" means an assembly of central vacuum-producing equipment and a network of piping for patient suction in medical, medical-surgical, and waste anesthetic gas disposal applications.
- (141) "**Mobile facility**" means a vehicle licensed and registered with the Kentucky Department of Transportation that contains plumbing fixtures and is intended for temporary use with regard to the structure it serves.
- (142) "**Modular**" means a structure or component that is wholly or substantially fabricated in an off-site manufacturing facility for installation at the building site.
- (143) "**Multiple dwelling**" means a building containing more than two (2) dwelling units.
- (144) "**NFPA**" means the National Fire Protection Association.
- (145) "**Nominal pipe size**" means a standard expression in inches and fractions thereof to designate the approximate inside diameter of a pipe, conduit, or tube.
- (146) "**Nonpotable water**" means water not safe for drinking, personal, or culinary use.
- (147) "**NSF**" means the National Sanitation Foundation.
- (148) "**Nuisance**" means dangerous to human life or detrimental to health, including:
- (a) A building, structure, or premise not sufficiently ventilated, sewered, drained, cleaned, or lighted, in reference to its intended or actual use; and
 - (b) An agent that renders the air, human food or drink, or a water supply unwholesome.
- (149) "**Nurses' station**" means an area in the nursing unit separated from the corridor by counter or desk, designed to permit nurses to:
- (a) Record and file each patient's history and progress;
 - (b) Observe observation, and control a corridor;
 - (c) Prepare medicines and
 - (d) Maintain contact with patients, the hospital, and the outside by local and public means of communication.
- (150) "**Offset**" means a combination of elbows or bends that bring one (1) section of the pipe out of line but into a line parallel with the other section.
- (151) "**Oil interceptor**" means "interceptor" as defined by this administrative regulation.
- (152) "**Parts or materials**" means all types of fittings and piping used in the soil, waste, and vent systems; house sewers; potable water supply; plumbing fixtures; appurtenances, and mechanical sewage systems in plumbing systems.
- (153) "**PE**" means polyethylene.
- (154) "**Person**" is defined by KRS 318.010(9).
- (155) "**PEX**" means cross-linked polyethylene pipe.
- (156) "**PEX-AL-PEX**" means polyethylene/aluminum/cross-linked polyethylene composite pressure pipe.
- (157) "**Pitch**" means "grade" as defined by this administrative regulation.
- (158) "**Plumbing**" is defined by KRS 318.010(4).

(159) **"Plumbing appliance"** means any one (1) of a special class of plumbing fixture that is intended to perform a special function. Its operation and control can be dependent upon one (1) or more energized components, such as motors, controls, heating elements, or pressure or temperature-sensing elements. Fixtures can operate automatically through one (1) or more of the following actions:

- (a) A time cycle;
- (b) A temperature range;
- (c) A pressure range;
- (d) A measured volume or weight; or
- (e) Manual adjustment or control by the user or operator.

(160) **"Plumbing appurtenance"** means a manufactured device, or a prefabricated assembly of component parts, and is an adjunct to the basic piping system and plumbing fixtures. An appurtenance demands no additional water supply, nor does it add any discharge load to a fixture or the drainage system. It is presumed that it performs some useful function in the operation, maintenance, servicing, economy, or safety of the plumbing system.

(161) **"Plumbing fixture":**

- (a) Means a receptacle or device that is either permanently or temporarily connected to the water distribution system of the premises, and demands a supply of water therefrom, or it discharges used water, liquid-borne waste materials, or sewage either directly or indirectly to the drainage system of the premises, or that requires both a water supply connection and a discharge to the drainage system of the premises; and
- (b) Does not mean piping that carries water or sewage.

(162) **"Plumbing inspector"** means a duly authorized employee or agent of the Department of Housing, Buildings and Construction who is charged with the responsibility of inspecting plumbing installations and with the enforcement of the Kentucky State Plumbing Code, KRS Chapter 318, and 815 KAR Chapter 20.

(163) **"Plumbing repair"** means, as used in the code, replacing a part or putting together a part or parts torn or broken.

(164) **"Plumbing system"** means appliances and water heaters; the water supply distributing pipes; the fixtures and fixture traps; the soil, waste, and vent pipes; the house drain and house sewer; and the storm water drainage within a building with their devices, appurtenances, and connections all within and adjacent to the building.

(165) **"Pool" means** "swimming pool" as defined by this administrative regulation.

(166) **"Potable water"** means water free from impurities present in amounts sufficient to cause disease or harmful physiological effects and conforming in its bacteriological and chemical quality to the requirements of the Division of Water in 401 KAR Chapter 8 and the Kentucky State Plumbing Code established in 815 KAR Chapter 20.

(167) **"Private" or "private use"** means, in the classification of plumbing fixtures, fixtures in residences, apartments, and private bathrooms of hotels, as well as similar installations in other buildings where the fixtures are intended for the use of a family or an individual.

(168) **"Private sewer"** means a sewer, serving two (2) or more buildings, privately owned, and not directly controlled by public authority.

(169) **"Public" or "public use"** means, in the classification of plumbing fixtures, fixtures in general toilet rooms of schools, gymnasiums, hotels, railroad stations, public buildings, bars, public comfort stations, and other installations (whether pay or free) where a number of fixtures are installed so that the fixtures use is similarly unrestricted.

(170) **"Public sewer"** means a common sewer directly controlled by public authority.

(171) **"Public water main"** means a water supply pipe for public use controlled by public authority.

(172) **"PVC"** means polyvinyl chloride.

(173) **"Receptor"** means a fixture or device that receives the discharge from indirect waste pipes.

(174) **"Relief vent"** means an auxiliary vent that permits additional circulation of air in or between drainage and vent systems.

(175) **"Replace"** means to put something new or rebuilt in the place of that which was existing.

(176) **"Return offset"** means a double offset installed so as to return the pipe to its original alignment.

(177) **"Revent pipe"** means "individual vent" as defined by this administrative regulation.

- (178) **"Rim"** means an unobstructed open edge of a fixture.
- (179) **"Riser"** means a water supply pipe that extends vertically one (1) full story or more to convey water to branches or to a group of fixtures.
- (180) **"Roof drain"** means a drain installed to receive water collecting on the surface of a roof and to discharge it into a leader or a conductor.
- (181) **"Roughing-in"** means the installation of all parts of the plumbing system that can be completed prior to the installation of fixtures. This includes drainage, water supply, vent piping, and the necessary fixture supports.
- (182) **"Safe waste"** means "indirect waste pipe" as defined by this administrative regulation.
- (183) **"Sand interceptor"** means "interceptor" as defined by this administrative regulation.
- (184) **"Sand trap"** means "interceptor" as defined by this administrative regulation.
- (185) **"Sanitary sewer"** means a sewer that carries sewage and excludes storm, surface, and ground water.
- (186) **"Scrub sink"** means a device usually located in the operating suite to enable operating personnel to scrub their hands prior to operating procedures. The hot and cold water supply is activated by a knee-action mixing valve or by wrist or pedal control.
- (187) **"SDR"** means standard dimensional ratio.
- (188) **"Seepage well or pit"** means a covered pit with open-jointed lining into which septic tank effluent is received that will seep or leach into the surrounding porous soil.
- (189) **"Separator" means "interceptor"** as defined by this administrative regulation.
- (190) **"Septic tank"** means a watertight receptacle that receives the discharge of a building sanitary drainage system or part thereof, and is designed and constructed so as to digest organic matter through a period of detention and allow the liquids to discharge into the soil outside of the tank through a system of open joint or perforated piping, or a seepage pit.
- (191) **"Sewage"** means any liquid waste containing animal or vegetable matter in suspension or solution, including liquids containing chemicals in solution.
- (192) **"Sewage ejector"** means a device for lifting sewage by entraining it in a high velocity jet of steam air or water.
- (193) **"Side vent"** means a vent connecting to the drain pipe through a fitting at an angle not greater than forty-five (45) degrees to the vertical.
- (194) **"Size of pipe and tubing" means "diameter"** as defined by this administrative regulation.
- (195) **"Slope"** means "grade" as defined by this administrative regulation.
- (196) **"Soil pipe"** means any pipe that conveys the discharge of water closets or similar fixtures, with or without the discharges from other fixtures, to the house drain.
- (197) **"Soil vent" means "stack vent"** as defined by this administrative regulation.
- (198) **"Special wastes"** means wastes that require special treatment before entry into the normal plumbing system.
- (199) **"Special waste pipe"** means pipes that convey special wastes.
- (200) **"Stack"** means any vertical line of soil, waste, or vent piping.
- (201) **"Stack group"** means a group of fixtures located adjacent to the stack so that by means of proper fittings, vents can be reduced to a minimum.
- (202) **"Stack vent"** means the extension of a soil or waste stack above the highest horizontal drain connected to the stack.
- (203) **"Stack venting"** means a method of venting a fixture or fixtures through the soil or waste stack.
- (204) **"Sterilizer, boiling type"** means a fixture (non-pressure type), used for boiling instruments, utensils, and other equipment (used for disinfection). Some devices are portable, while others are connected to the plumbing system.
- (205) **"Sterilizer, instrument"** means a device for the sterilization of various instruments.
- (206) **"Sterilizer pressure (autoclave)" or "autoclave"** means a fixture (pressure vessel) designed to use steam under pressure for sterilizing.
- (207) **"Sterilizer, pressure instrument washer-sterilizer"** means a fixture (pressure vessel) designed to both wash and sterilize instruments during the operating cycle of the fixture.
- (208) **"Sterilizer, utensil"** means a device for the sterilization of utensils as used in hospital services.

- (209) "**Sterilizer vent**" means a separate pipe or stack, indirectly connected to the building drainage system at the lower terminal, which receives the vapors from non-pressure sterilizers, or the exhaust vapors from the pressure sterilizers, and conducts the vapors directly to the outer air. Sometimes a sterilizer vent is referred to as vapor, steam, atmospheric, or exhaust vent.
- (210) "**Sterilizer, water**" means a device for sterilizing water and storing sterile water.
- (211) "**Still**" means a device used in distilling liquids.
- (212) "**Storm drain**" means building storm drain.
- (213) "**Storm sewer**" means a sewer used for conveying rain water, surface water, condensate, cooling water, or similar liquid wastes.
- (214) "**Subsoil drain**" means a drain that collects subsurface water and conveys it to a place of disposal.
- (215) "**Sump**" means a tank or pit, which receives sewage or liquid waste, located below the normal grade of the gravity system and that is emptied by mechanical means.
- (216) "**Sump pump**" means a mechanical device, other than an ejector or bucket, for removing sewage or liquid waste from a sump.
- (217) "**Supports**" means devices for supporting and securing pipe, fixtures, or equipment.
- (218) "**Swimming pool**" means any structure, basin, chamber, or tank containing any artificial body of water for swimming, diving, wading, or recreational bathing.
- (219) "**Temporary**" means a period of time not to exceed thirty (30) days of intermittent or continual use within twelve (12) month period on the same premises.
- (220) "**Trap**" means a fitting or device that provides a liquid seal to prevent the emission of sewer gases without materially affecting the flow of sewage or waste water through it.
- (221) "**Trap arm**" means that portion of a fixture drain between a trap and its vent.
- (222) "**Trap primer**" means a device or system of piping to maintain a water seal in a trap, typically installed where infrequent use of the trap would result in evaporation of the trap seal, such as floor drains.
- (223) "**Trap seal**" means the vertical distance between the crown weir and the top of the dip of the trap.
- (224) "**Utility room**" means a workroom in the patient nursing area, designed and equipped to facilitate preparation, cleaning, and incidental sterilizing of the various supplies, instruments, and utensils involved in nursing treatment and care, exclusive of medications handled in nurses' stations and bedpan cleaning and sterilizing.
- (225) "**Vacuum**" means any pressure less than exerted by the atmosphere.
- (226) "**Vacuum breaker**" means "backflow preventer" as defined by this administrative regulation.
- (227) "**Vacuum breaker, non-pressure type (atmospheric)**" means a vacuum breaker that is not designed to be subjected to static line pressure.
- (228) "**Vacuum breaker, pressure type**" means a vacuum breaker designed to operate under conditions of static line pressure.
- (229) "**Vent pipe**" means any pipe provided to ventilate a house drainage system and to prevent tray siphonage and back pressure.
- (230) "**Vent system**" means a pipe or pipes installed to provide a flow of air to or from a drainage system or to provide a circulation of air within the system to protect trap seals from siphonage and back pressure.
- (231) "**Vertical pipe**" means any pipe or fitting that makes an angle of forty-five (45) degrees or less with the vertical.
- (232) "**Wall hung water closet**" means a wall mounted water closet installed in such a way that no part of the water closet touches the floor.
- (233) "**Waste pipe and special waste**" means any pipe that receives the discharge of any fixture (except water closets or similar fixtures) and discharges to the house drain, soil, or waste stacks. If a pipe does not connect directly with a house drain, waste, or soil stack, the pipe is considered to contain special waste.
- (234) "**Water closet**" means a flush toilet.
- (235) "**Water distributing pipe**" means a pipe within the building or on the premises that conveys water from the water-service pipe or meter to the point of usage.
- (236) "**Water heater**" means "water heating device," as defined by KRS 318.200(1).
- (237) "**Water lifts**" means "sewage ejector" as defined by this administrative regulation.

- (238) **"Water outlet"** means a discharge opening through which water is supplied to a fixture, into the atmosphere (except into an open tank that is part of the water supply), to a boiler or heating system, or to any devices or equipment requiring water to operate but that are not part of the plumbing system.
- (239) **"Water riser pipe"** means "riser" as defined by this administrative regulation.
- (240) **"Water service pipe"** means the pipe from the water main or other source of potable water supply to the water distributing system of the building served.
- (241) **"Water supply stub"** means a vertical pipe less than one (1) story in height supplying one (1) or more fixtures.
- (242) **"Water supply system"** means the water service pipe, the water-distributing pipes, and the necessary connecting pipes, fittings, control valves, and all appurtenances in or adjacent to the building or premises.
- (243) **"Well, bored"** means a well constructed by boring a hole in the ground with an auger and installing a casing.
- (244) **"Well, drilled"** means a well constructed by making a hole in the ground with a drilling machine of any type and installing casing and screen.
- (245) **"Well, driven"** means a well constructed by driving a pipe in the ground. The drive pipe is usually fitted with a well point and screen.
- (246) **"Well, dug"** means a well constructed by excavating a large diameter shaft and installing a casing.
- (247) **"Wet vent"** means a vent that receives the discharge of wastes other than from water closets.
- (248) **"Yoke vent"** means a pipe connecting upward from a soil or waste stack to a vent stack for the purpose of preventing pressure changes in the stack. (Recodified from 401 KAR 1:010, 7-5-1978; Am. 9 Ky.R. 827; eff. 2-2-1983; 12 Ky.R. 1659; eff. 5-6-1986; 13 Ky.R. 779; eff. 11-11-1986; 950; eff. 12-2-1986; 14 Ky.R. 1116; eff. 1-4-1988; 16 Ky.R. 2758; 17 Ky.R. 1092; eff. 8-22-1990; 20 Ky.R. 3112; eff. 7-7-1994; TAm eff. 8-9-2007; 43 Ky.R. 615, 987; eff. 1-6-2017; 46 Ky.R. 1637, 2409; eff. 6-2-2020.)

815 KAR 20:020. Parts or materials list.

RELATES TO: KRS 318.010, 318.015, 318.130, 318.150, 318.200

STATUTORY AUTHORITY: KRS 198B.040(10), 318.130

NECESSITY, FUNCTION, AND CONFORMITY: KRS 318.130 requires the department to promulgate an administrative regulation establishing the Kentucky State Plumbing Code regulating plumbing, including the methods and materials that may be used in Kentucky. This administrative regulation establishes an Approved Parts or Materials List containing the parts and materials that have been approved for use in Kentucky.

Section 1. Approved Parts or Materials List APML. (1) A part or material manufactured or produced according to a specification listed in the code shall be considered approved if it meets the latest edition of the specification.

(2) Drainage or plumbing systems shall only use parts and materials that:

(a) Are currently authorized by the code; or

(b) Have been considered and approved by the department as being equal to or better than other similarly approved items for inclusion in the APML.

(3) The APML may specify methods of installation or restrictions applicable to a particular part or material.

Section 2. Amending the APML. (1) A person may petition the division, in writing, to amend the APML. The request shall include:

(a) A description of the part or material for which approval is sought;

(b) Available technical data;

(c) A listing of other authorities that have approved the use of the part or material; and

(d) Any other pertinent information requested by the division.

(2) (a) The division shall consider all parts or materials for which approval is sought and shall forward its recommendations within thirty (30) days to the department.

(b) Upon approval of a recommendation by the department, the APML shall be amended by listing the new part or material in Section 4 of this administrative regulation.

(c) Following the determination by the department, a person having an interest in the subject matter may request a hearing on the determination within thirty (30) days.

Section 3. Custody of the APML. The Director, Division of Plumbing, shall maintain an up-to-date APML and make it available for inspection during regular office hours. Copies of the APML may be obtained by mailing a self-addressed stamped envelope to the Division of Plumbing, Department of Housing, Buildings and Construction, 500 Mero Street, Frankfort, Kentucky 40601-5412.

Section 4. Content of APML. The following list of parts or materials have been reviewed and approved by the department and shall be allowed for installation in Kentucky:

(1) Flexible three-fourths (3/4) inch hot and cold water connectors for hot water heaters, minimum wall thickness, 0.032;

(2) (a) Flushmate water closet tank;

(b) Microphor company. Two (2) quart flush toilets;

(c) Jomar 3 and 4 water conserver water closets to operate efficiently on three and one-half (3 1/2) gallons of water per flush;

(d) Superinse toilet that operates on one (1) gallon of water per flush as manufactured by Universal Rundle for the Thetford Wastewater Treatment Systems;

(e) IFO Sanitar AB Model-3160 and 3180 China Water Closet equipped with a Fluidmaster 4003A-F77 Ballcock;

(f) Cashesaver MX (quantum 150-1) Water Closet Combination and Flushmate II Flushometer/Tank as manufactured by Mansfield Plumbing Products; and

- (g) Dual flush water closets by Caroma, USA. The water closets shall use zero and eight-tenths (0.8) gallons for the short flush cycle and one and six-tenths (1.6) gallons for the full flush cycle;
- (3) Tubular traps with gasket in trap seal;
- (4) (a) PE sump pump basin. PE sump pump basin shall be constructed of PE material and shall be provided with a sump cover;
- (b) Liberty Pump Model 402, Laundry Tray Pump for pipe size one and one-half (1 1/2) inch for light commercial and household usage;
- (c) Zoeller Drain pump and HiLo Industries Power Drain for pipe sizes one and one-half (1 1/2) inch and two (2) inch for light commercial and household usage;
- (d) Little Giant Pump Company, Drainosaur Water Removal System, Model #WRS-6. This approval shall be limited to two (2) drainage fixture units because it has a one and one-half (1 1/2) inch drain;
- (e) Add A Drain (Waste Discharge System) as manufactured by Lunsford and Associates;
- (f) Sta-Rite Pump Corporation, laundry tray system approved for residential and light commercial use; and
- (g) Electric Drain System as manufactured by Myers for light commercial and household usage;
- (5) (a) No-caulk roof flashing. No-caulk roof flashing shall be eighteen (18) inch by eighteen (18) inch galvanized iron base with a neoprene boot forming a water tight seal with the stack that it serves;
- (b) PE roof flashing. PE roof flashing shall have a base that shall extend six (6) inches in all directions from the base of a stack and shall have a boot with a preformed thermoplastic rubber gasket;
- (c) Dektite pipe flashing system to be used on metal building decks for plumbing vent stacks as manufactured by Buildex Corporation;
- (d) Oatey eighteen (18) inch by eighteen (18) inch no caulk thermoplastic flashing, one (1) piece construction, positive double seal in three (3) inch only;
- (e) Carlisle syntec systems. Vent flashings for sureseal and Brite-Ply roofing systems as required by Carlisle Corporation;
- (f) Trocal roofing systems. Vent flashings for Trocal roofing systems as required by Dynamit Nobel of American, Inc;
- (g) Masterflash Pipe Flashing system for plumbing vent stacks as manufactured by Aztec Washer Company; and
- (h) Hi-Tuff Roofing Systems pipe flashing system for plumbing vent stacks as required by J.P. Stevens and Company, Inc;
- (6) (a) Kitchen sink faucet. Kitchen sink faucets may have corrugated supply piping if the piping has a wall thickness equal to Type M copper pipe;
- (b) Sink and lavatory faucets and pop-up lavatory assembly parts manufactured by CPVC plastic as manufactured by Nibco Co.; and
- (c) Series 1000 Automatic Faucets as Manufactured by Hydrotek USA, Inc;
- (7) Lab-Line Enfield L-E acid waste systems, one and one-half (1 1/2) through four (4) inch inside measurement for above and below ground installation on acid waste. Underground shall be laid on six (6) inches of sand grillage and shall be:
- (a) Backfilled by hand and tamped six (6) inches around piping; and (b) Surrounded by six (6) inches of sand grillage;
- (8) Floor drains, shower drains, urinal drains, and clean-outs manufactured by Plastic Oddities, Inc;
- (9) Tubular plastic components conforming to ASTM F409-75, bathtub waste and overflow, traps, continuous sink wastes, and extension tubes as manufactured by J & B Products Corporation;
- (10) (a) **Water heaters.** Heat pump water heaters as manufactured by:
1. Dec International, Inc., Therma-Stor Products Group; or
 2. Steibel Eltron Accelera 300. If the water heater is shipped with a 100 PSI Pressure and Temperature Relief Valve, it shall be replaced with a 150 PSI Pressure and Temperature Relief Valve; and
- (b) Water heaters, point of use or instantaneous.

1. In-Sink-Erator's Ultra System. For instant hot water to serve individual fixtures, Model #777W, W, WH, WA and WHA, W-152 and W-154;
2. Eemax Electric Tankless water heaters.
 - a. Nonpressure type without the requirement of a temperature and pressure relief valve; or
 - b. The pressure type with the requirements that the temperature and pressure relief valve be of a one-half (1/2) inch short shank valve and be installed with the product;
3. Vitaclimate Control Systems, Inc. - Heatrae Instantaneous Water Heaters Models 7000 and 9000, pressure type, point of use water heater, which shall be equipped with an approved temperature and pressure relief valve installed so that the thermocouple of the relief valve extends into the heat chamber discharge;
4. Paloma Automatic Instantaneous Gas Water Heaters Numbers PH-6DN, PH-6DP, PH-12A-DN, PH-12A-DP, PH-12M-DN, PH-12M-DP, PH-16A-DN, PH-16A-DP, PH-16M-DN, PH-16M-DP, PH-24A-DN, PH-24A-DP, PH-24M-DN, and PH-24M-DP;
5. Rinnai Gas Fired Instantaneous Water Heaters Model Numbers REU-95GS-2R, REU-95GS-3R, REU-90, REU-130, REU-V2520 FFU-US, REU-V2520 FFUC-US, REU-V2020W-US, REU-V2020WC-US, and REU-V1616W-US pressure type, which shall be equipped with an approved pressure relief valve;
6. Elkay Aqua-Temp tankless water heaters – non-pressure type without the requirement of a temperature and pressure relief valve;
7. International Technology Sales Corporation AEG Telefunken MDT instantaneous water heater, which shall be equipped with an approved pressure relief valve;
8. International Technology Sales Corporation Zanker Faucet Model W05U without a temperature and pressure relief valve;
9. Amtrol hot water maker model numbers WH7P, WH7 and WH7C with a minimum three- fourths (3/4) inch inlet and outlet;
10. Chromomite Laboratories, Inc. - instantaneous water heater, which shall be equipped with an approved pressure relief valve;
11. Chromomite Instant-Flow Tankless Water Heater without a temperature and pressure relief valve;
12. Nova Hot Water Generator Models: VES5/10, VES6/12, VES7/14, VES8/16, VES9/18, and VES11/22 as manufactured by Hot Water Generators, Inc;
13. Aqua Star tankless gas water heaters, model numbers 125 VP and 80 VP, which shall be equipped with an approved pressure relief valve;
14. Ariston electric water heaters, model numbers P-15S and P-10S, which shall be equipped with an approved pressure relief valve;
15. Vaillant Corporation gas fired point of use water heater;
16. Trinom Hot Man Tankless Water Heater as manufactured by Siemens;
17. Field Controls Company Power Venter - Models PVAE and SWG for use in conjunction with gas and oil fired water heaters;
18. Acutemp Instantaneous Water Heater as manufactured by Keltech, Inc., Model #100/208, #100/240, #150/208, #150/240, #180/208, #180/240, #153/208, #153/240, #183/208, #183/240, #183/480, and #C183/480;
19. Hot Aqua Instantaneous Tankless Electric Water Heaters, Model Numbers, 18/125PC, 24/125PC, 24/120, 32/120, 24/240, 36/240, 48/240, 59/240, 70/240, 24/208, 35/208, 46/208, 60/208, 28/277, 42/277, 55/277, 69/277, 24/120-P, 59/240-P, 46/208-P, 55/277-P, 18/125PC, and 24/125PC. This product shall not be approved for supplying hot water for showers;
20. Stiebel Eltron Tankless Water Heater.
 - a. Models DHC 3, DHC 6, and DHC 8 approved for use with lavatories and sinks;
 - b. Models Temptra/DHC-E 8/10 and DHC-E 12;

c. Models Mini 2, Mini 3, Mini 4, and Mini 6 Point of Use tankless electric water heaters; and

d. Models 12/2 Plus, 15/15 Plus, 20/20 Plus, 24/24 Plus, 29 Plus, and 36 Plus;

21. Bosch Aqua Star tankless water heater. Models 125X, 125B, 125S, 125BS, 125FX, and 38B. All models shall be installed with pressure relief valves;

22. Controlled Energy Corporations "Powerstream" tankless water heater;

23. Ariston mini tank electric water heaters in 2.5, 4, and 6 gallon models;

24. Powerstar PS19T and PS28T Electric Instantaneous Water Heater, as manufactured by Controlled Energy Corporation, to be installed with pressure relief valves;

25. Aquastar AQ240 FX (LP, NG) gas fired instantaneous water heater, as manufactured by Controlled Energy Corporation, to be installed with pressure relief valve;

26. S.E.T.S. Tankless Water Heater Models: #220, #180, #165, and #145 to be installed with temperature and pressure relief valve;

27. Rinnai Continuous Flow Water Heaters: Models 2532FFU(-C), 2532W(-C), 2532FFU, and 2424W(-C) all requiring an approved pressure relief valve;

28. Noritz American Corporation Tankless, Instantaneous Water Heater Models: N-042, N-063 to be installed with pressure relief valve;

29. Takagi Industrial Company USA, Inc., Instantaneous Water Heaters, Models: T-KLS, T-K JR, T-K2, and T-KD20 to be installed with pressure relief valve;

30. Envirotech Systems ESI 2000 Series Tankless Water Heaters, all requiring an approved pressure relief valve;

31. QuietSide Instantaneous Water Heater Models: QVW8 - 100, 120, 175. All models shall be equipped with an approved temperature and pressure relief valve and temperature preset at 120 degrees;

32. Seisco Tankless Water Heaters Model:

a. Point-of-Use Single Chamber Models: POU24, POU30, POU35, POU40, POU45, POU55, POU60, POU70, POU73, POU78, POU80, POU90, POU140, SC90, and SC140. These models shall not require the installation of a temperature and pressure relief valve;

b. Residential Single Phase Models: RA14, RA16, RA18, RA22, RA24, RA28, and RA32. These models shall not require the installation of a temperature and pressure relief valve;

c. Commercial Single Phase Models: CA14, CA16, CA18, CA22, CA24, CA28, and CA32. These models shall not require the installation of a temperature and pressure relief valve;

d. Commercial Three (3) Phase Models: CA9-3, CA10-3, CA12-3, and CA14-3. These models shall not require the installation of a temperature and pressure relief valve; and

e. Electric Mini-Tank Models: SMT2.5, SMT4, and SMT6. These models require the installation of a temperature and pressure relief valve supplied by the manufacturer;

(11) Compression joints. Fail-safe hot and cold water systems;

(12) Orion fittings for acid waste piping systems for above and below ground;

(13) R & G Slone Manufacturing Company. Fuseal mechanical joint for the connection of polypropylene and waste piping;

(14) Johns Manville Flex I drain roof drain system;

(15) Hydrocide liquid membrane (HLM) to be used as a shower pan material conforming to ASTM C836-76. The density of the material shall be at least one-sixteenth (1/16) inch thick;

(16) Scotch-Clad brand waterproofing system as manufactured by the 3M Company for thin set installation of ceramic and quarry tile in shower stalls, bathrooms, and janitorial closets limited to those applications on concrete floors and using metallic soil and waste piping;

(17) Elkay Aqua-chill water dispensers;

- (18) Flexible connectors for hot and cold potable water supply in plumbing fixture connections as manufactured by Aqua-Flo Corporation limited to thirty (30) inch length except dishwashers, which shall be forty-eight (48) inches maximum;
- (19) (a) Delta Faucet Company's quick-connect fitting known as "grabber" to be used with hot and cold potable water installations above ground only;
 (b) REMCO Angle Stop Quick connect valve for use with hot and cold potable water installations above ground only; and
 (c) Red White Valve Corporation. Reduced port polypropylene ball valves designed for installation on fusion welded polypropylene piping systems compliant with NSF standards 61 and 14 and ASTM F2389;
- (20) Interceptors:
- (a) Town and Country plastic interceptors to be used as a grease trap;
 (b) Grease recovery unit (GRU) as manufactured by Lowe Engineering, Lincoln Park, NJ;
 (c) Scienco, Inc., models SI-101-20G, SI-104-35G, SI-102-50G, and SI-103-100G with PVC solvent connections;
 (d) Rockford separators for grease, oil, hair and solids in various styles and sizes and being more specifically model series G, G LO, G M, G LOM, GF, GFE, GAS, GPS, GSS, OS, RHS, GSC, RMS, RSD, SD, SDE, GTD, and RTD that are used for their intended purpose and in-stalled in accordance to the manufacturer's specification and the plumbing code;
 (e) Grease interceptors as manufactured by Enpoco, Inc. of St. Charles, IL;
 (f) Grease Traps U.S.A.: Polypropylene grease trap, model number GT-25, as certified by the Plumbing and Drain Institute;
 (g) Schier Grease Interceptors Trapper II Series meeting ASME 112.14.3 Model numbers 1820, 2025, 2635, and 3050;
 (h) Schier Grease Interceptors Great Basin Series meeting ASME 112.14.3 Model numbers GB-75 and GB-250 approved only with the installation of two-directional, accessible cleanouts on the inlet and the outlet. The discharge of garbage disposals shall not be permitted; and
 (i) Thermaco Inc. models TZ600 (150 GPM), TZ 400 (75 GPM), and the TZ 160 (35 GPM). These interceptors shall be installed with a full size vent (three (3) or four (4) inches as applicable per manufacturer's instructions to the model being installed), located on the outlet side of the interceptor and returned to the vent stack or located so that it terminates a minimum of twelve (12) inches above the ground;
- (21) Plastic Oddities Srv (sewer relief vent) clean-out;
- (22) Contech A-2000 - a PVC corrugated pipe with smooth interior meeting or exceeding all the material and service test requirements of ASTM D-3034-06 except dimensions at the time of manufacture;
- (23) Nonchemical water treatment to control lime scale and corrosion buildup superior water conditioners as manufactured by Kemtune, Inc;
- (24) Eljer plumbing ware - Elgers ultra one/G water closet;
- (25) (a) "Power Flush" and "Quik Jon" as manufactured by Zoeller Company, which shall have a three (3) inch vent and alternate additional waste openings shall be located in the pump chamber above the top of the base chamber; and
 (b) Hydromantic JB-1 System as manufactured by Hydromantic Pumps, Inc.;
- (26) Exemplar Energy garden solar water heater;
- (27) ProSet systems for pipe penetrations in fire rated structures. System A for copper and steel pipe. System C using solvent weld joints only. Proset E-Z flex coupling shall be approved for similar or dissimilar materials;
- (28) (a) ABS and PVC backwater valves, Models 3281, 3282, 3283, and 3284 for solvent cement joints only as manufactured by Canplas Industries;
 (b) Flood-Gate Automatic Backwater Valve as manufactured by Bibby-Ste-Croix; and
 (c) Fullport Backwater Valve as manufactured by Mainline Backflow Products, Inc.;
- (29) Clamp-All Corporation Pipe Coupling Systems shall be approved size for size on dissimilar materials on new or existing installations. The use of Snap-All Increaser/Reducer transition bushings shall be included in this approval;

- (30) Mission Rubber Company "Band-Seal Specialty Coupling" shall be approved as a transition between any combination of the following materials: cast iron, copper, galvanized steel, schedule 40 PVC and ABS, and SDR 35;
- (31) (a) Laticrete 9235 Waterproof Membrane to be used as a safing material for floors and walls in showers, bathtubs, and floor drain pans;
(b) Ultra-Set as manufactured by Bostik Construction Products to be used as a water proofing material;
- (32) DFW Elastomeric PVC coupling manufactured by DFW Plastics, Inc. for use on building sewers;
- (33) (a) Fernco Lowflex Shielded Couplings, approved for connecting extra heavy, no-hub, and service weight cast iron pipe, DWV PVC and ABS pipe, SDR 35 sewer pipe, galvanized steel pipe, and copper pipe or as a transition between any of these materials in soil waste and vent systems above or below grade; and
(b) Fernco Proflex Shielded Couplings: Series 3000 for service weight cast iron to plastic, steel, or extra cast iron in sizes one and one-half (1 1/2) inch to four (4) inch, Series 3001 for cast iron, plastic, or steel to copper in sizes one and one-half (1 1/2) inch to two (2) inch; and Series 3003 for copper to copper in one and one-half (1 1/2) inch;
- (34) TBA drain, waste and vent pipe, schedule 40 PVC piping marked "meets dimensional specifications of ASTM D-2665". This pipe shall have been tested for the tensile strength, durability, of ASTM D-2665 except that it is made from recycled, unused plastics rather than virgin materials;
- (35) Blucher-Josam stainless steel pipe, fittings, and drains for disposal of corrosive wastes;
- (36) Paul Panella Industries Hostalen GUR UHMW Polymer Cleanout approved for use on sewers of Schedule 40 PVC, ABS, and SDR in four (4) inch and six (6) inch sizes;
- (37) Advanced Drainage Systems, Inc., Series 35 polyethylene corrugated sewer pipe with a smooth interior for underground storm water drainage within a building;
- (38) "Flowguard Gold" one (1) step CPVC cement for joining copper tube size CPVC piping systems through two (2) inches without the requirement of a cleaner or primer;
- (39) E-Z Trap Adapter as manufactured by S & S Enterprises to be used as connection between chrome plated P trap and PVC waste line;
- (40) (a) Canplas Industries LTD Specialty DWV Fittings: Part #3628 ABS or PVC forty-five (45) degree Discharge Closet Flange, Part #2321 Appliance (dishwasher) Wye, and Part #3650A Closet Flange Kit for Concrete Installations; and
(b) Flo-Bowl Waxless Leakless Toilet System as manufactured by Flo-Bowl Systems Inc.;
- (41) (a) Conbraco 78-RV Series In-Line Water Heater Shut-Off Thermal Expansion Control Valve preset at 125 psi to relieve thermal expansion; and
(b) Watts Regulator BRV Expansion Relief Valve to relieve thermal expansion;
- (42) Plastic Productions PVC "Quick Stub" approved as a solvent weld transition between tubular PVC and schedule 40 PVC;
- (43) HubSett In Line Test Coupling: PVC and ABS test couplings produced by HubSett Manufacturing Inc. for testing soil waste and vent systems;
- (44) Viega/Ridgid ProPress System: Copper press fittings for joining copper water tubing and using an elastomeric o-ring that forms the joint.
(a) The fitting shall be made by pressing the socket joint under pressure in accordance with the manufacturer's installation requirements; and
(b) This system shall be approved for pipe sizes one-half (1/2) inch through four (4) inch for above slab installations only;
- (45) TRIC Trenchless Systems for replacement sewers in four (4) inch and six (6) inch sizes.
(a) A video recording of the existing sewer shall be made to determine proper alignment and reviewed by the plumbing inspector;
(b) After the installation is complete, another video recording shall be reviewed by the plumbing inspector to ensure that the installation was successful;
(c) The sewer shall be tested according to 815 KAR 20:150; and
(d) The interior heat fusion bead shall be removed to provide a smooth surface with no obstruction;

- (46) Envirovac Inc.: Evac Vacuum Systems Condensate Collection System approved for condensate collection and the discharge from lavatories only;
- (47) Macerating Systems from Sanitary-for-All, consisting of a sump with a macerating pump, with or without a macerating toilet. The sump shall be air tight and provided with a minimum one and one-fourth (1 1/4) inch vent. These systems shall be installed in accordance with the manufacturer's recommendations and shall not be used as a primary means of waste disposal;
- (48) Rhino Wet Waste Interceptor manufactured by Ecosystems Inc. to be used as a prefiltration of wet wastes before discharging to a grease trap or interceptor;
- (49) Quick Snap Multi Level Flange as manufactured by Jett Plumbing Products, Inc;
- (50) Sioux Chief Manufacturers Stainless Steel Swivel Ring Closet Flange;
- (51) Service Weight and No-Hub Cast Iron Pipe and Fittings furnished by DWV Casting Company complying with ASTM A74 and A888 and CIPI 301-00;
- (52) American Pipe Lining, Inc. APL 2000, which is an epoxy lining used in restoring water distribution systems. The use of APL 2000 shall comply with paragraphs (a) through (d) of this subsection.
- (a) A plumbing construction permit shall be required.
 - (b) Installation shall be by a licensed plumber.
 - (c) Water quality shall be tested before and after each project.
 - (d) A water distribution system treated with APL 2000 shall be clearly marked on all exposed piping and the water heater with the following notice: "FLAMELESS TECHNIQUES MUST BE USED FOR ALL REPAIRS AND MODIFICATIONS TO THIS PIPING SYSTEM";
- (53) Base Products Corporation.
- (a) Water powered pump: basepump. Each model shall:
 1. Be installed with a reduced pressure principle backflow preventer with copper piping only;
 2. Be approved for groundwater removal only; and
 3. Require incoming water pressure of 50 psi to operate; and
 - (b) Battery backup pump: hydropump;
- (54) Perma-Liner Industries, Inc, Lateral Lining System.
- (a) This system shall be approved for pipe sizes three (3) inches through eight (8) inches for interior and exterior installations.
 - (b) Interior applications shall be video recorded before and after installation and shall have a water or air test as required by 815 KAR 20:150, Section 4(2) or (3).
 - (c) Exterior applications shall be video recorded before and after and shall have a smoke test to comply with 815 KAR 20:150, Section 4(6).
 - (d) A permit shall be obtained prior to an exterior or interior application;
- (55) Stainless steel piping system for potable water applications manufactured by Victaulic for above ground applications only;
- (56) Wallgate Classic Model CME recessed and molded handwasher/dryer;
- (57) MaxLiner.
- (a) This system shall be approved for pipe sizes three (3) inch through ten (10) inch for interior and exterior installations.
 - (b) Interior applications shall be video recorded before and after installation and shall have a water or air test as required in 815 KAR 20:150, Section 4(2) or (3).
 - (c) Exterior applications shall be video recorded before and after installation and shall have a smoke test to comply with 815 KAR 20:150, Section 4(6).
 - (d) Permits shall be required for both interior and exterior applications;
- (58) Nuflow Technologies Inc., Nuflow System.
- (a) This system shall be approved for pipe sizes one and one-half (1 1/2) inch through twelve (12) inch for interior and exterior installations.
 - (b) Interior applications shall be video recorded before and after installation and shall have a water or air test as required in 815 KAR 20:150, Section 4(2) or (3).
 - (c) Exterior applications shall be video recorded before and after installation and shall have a smoke test to comply with 815 KAR 20:150, Section 4(6).

- (d) Permits shall be required for both interior and exterior applications;
- (59) Schluter Shower System for waterproofing tiled shower installations installed per manufacturer recommendations;
- (60) WATCO Manufacturing Watco Flex and Watco Flex 900 Innovator tub waste and overflow;
- (61) J.R. Smith MFG. CO. THE BOSS TEE Series 4505 cleanout tee;
- (62) Pipe Patch NO-Dig Repair System by Source One Environmental.
 - (a) The repair shall require a plumbing installation permit issued by the department; and
 - (b) After the repair has been completed, the building sewer shall be inspected, tested with either a water or a smoke test, and approved by the department;
- (63) PHIX Cartridge Systems. The PHIX cartridge system shall be approved for use as a point-source or in-line acid neutralization system;
- (64) SharkBite Evopex polymer fittings meeting ASSE Standard 1061. The use of SharkBite Evopex polymer fittings shall be approved for underground burial except the fitting shall not be buried:
 - (a) Under or encased in concrete, or
 - (b) Underground beneath a building; and
- (65) SharkBite Universal DZR brass fittings or SharkBite EvoPEX DZR brass transition fittings meeting ASSE Standard 1061. The use of these fittings shall be approved for underground burial if the fitting is:
 - (a) Wrapped with self-fusing, formaldehyde-free and chloride-free, fully cured silicone tape with a minimum thickness of 0.020 inches;
 - (b) Not buried under or encased in concrete; and(c) Not buried underground beneath a building.

(Recodified from 401 KAR 1:011, 7-5-1978; Am. 14 Ky.R. 1123; eff. 1-4-1988; 15 Ky.R. 1580; 1799; eff. 2-3-1989; 2446; eff. 7-26-1989; 16 Ky.R. 901; eff. 1-12-1990; 2274; eff. 6-7-1990; 17 Ky.R. 472; eff. 10-14-1990; 2266; eff. 3-13-1991; 3278; eff. 7-519-91; 18 Ky.R. 1228; 1884; eff. 12-8-1991; 2717; eff. 4-3-1992; 19 Ky.R. 295; 730; eff. 9-10-1992; 997; 1383; eff. 12-8-1992; 2503; eff. 7-12-1993; 20 Ky.R. 650; eff. 11-8-1993; 2159; eff. 3-14-1994; 21 Ky.R. 575; eff. 10-10-1994; 22 Ky.R. 796; eff. 12-7-1995; 1383; eff. 3-7-1996; 2119; eff. 7-5-1996; 23 Ky.R. 1754; 2501; eff. 12-11-1996; 3972; eff. 6-25-1997; 24 Ky.R. 957; eff. 12-15-1997; 2460; eff. 12-15-1997; 25 Ky.R. 2959; 26 Ky.R. 386; eff. 8-16-1999; 1046; eff. 1-11-2000; 27 Ky.R. 228; eff. 9-11-2000; 1348; eff. 1-15-2001; 3163; 28 Ky.R. 87; eff. 7-16-2001; 937; eff. 12-19-2001; 2271; eff. 7-15-2002; 29 Ky.R. 2988; eff. 8-13-2003; 30 Ky.R. 1601; eff. 2-16-2004; 2390; 31 Ky.R. 85; eff. 8-6-2004; 32 Ky.R. 365; 657. eff. 11-4-2005; 32 Ky.R. 2357; 33 Ky.R. 400; eff. 9-1-2006; 400; 3258; eff. 7-6-2007; 34 Ky.R. 1232; 1744; eff. 2-1-2008; 35 Ky.R. 2582; 36 Ky.R. 80; 7-29-2009; 37 Ky.R. 186; 732; eff. 10-1-2010; 39 Ky.R. 151; 485; eff. 10-5-2012; 39 Ky.R. 2203; eff. 8-2-2013; 43 Ky.R. 455, 685; eff. 11-16-2016; 46 Ky.R. 1643, 2414; eff. 6-2-2020.)

815 KAR 20:030. Plumbing License

RELATES TO: KRS 318.010, 318.020, 318.030, 318.040, 318.050, 318.054, 318.060, 318.080

STATUTORY AUTHORITY: KRS 198B.040(10), 318.040(1)(d), (2), (3), 318.050, 318.054(3), 318.130
NECESSITY, FUNCTION, AND CONFORMITY: KRS 318.130 requires the Department of Housing, Buildings and Construction to promulgate and amend the Kentucky State Plumbing Code to regulate plumbing. KRS 318.040(1)(d) authorizes the commissioner to promulgate administrative regulations establishing qualifications for a master plumber's license and a journeyman plumber's license. KRS 318.040(2) and (3) require the department to establish examination requirements and procedures. KRS 318.050 requires the department to establish reasonable application fees for licensure as a master plumber or journeyman plumber. KRS 318.054(3) requires the department to establish reasonable renewal fees for master plumbers and journeyman plumbers. This administrative regulation establishes the application, examination, and renewal requirements for master plumbers and journeyman plumbers.

Section 1. Examinations. (1) Examination applications.

- (a) All examination applicants for any plumber's license shall submit to the department:
 - 1. A completed Plumbing Examination Registration Form, Form PLB-3;
 - 2. The appropriate non-refundable examination fee:
 - a. For a master plumber, \$150; or
 - b. For a journeyman plumber, fifty (50) dollars; and
 - 3. A passport-sized color photograph of the applicant taken within the past six (6) months.
- (b) If an applicant fails to successfully complete the appropriate examination within one (1) year from the date of the first notice of examination, the application shall be void.

(2) Examination design.

- (a) The State Plumbing Examining Committee shall design the examination requirements.
- (b) All examinations shall include:
 - 1. Written questions pertaining to basic principles of plumbing, KRS Chapter 318, 815 KAR Chapter 2, and 815 KAR Chapter 20; and
 - 2. Inserting the proper pipe size on a prepared drawing that indicates all stacks, wastes, and vents and the connected plumbing fixtures.
 - a. The proper sizing of main stacks shall be given more importance than other piping.
 - b. Deductions shall be required for oversized piping and for undersized piping.
 - 3. The journeyman plumber's license examination shall include a practical section in which the applicant shall demonstrate the ability to properly install plumbing by engaging in certain activities, such as making proper connections of various plumbing materials.
 - a. An applicant for a journeyman plumber's license examination shall furnish the plumbing materials required for the practical examination.
 - b. The department shall notify the applicant at least one (1) week prior to the date of examination as to what plumbing materials are needed.
 - 4. The examination requirements shall be more complex for the master plumber's license examination than the journeyman plumber's license examination.

(3) Examination schedule.

- (a) Regular examination of applicants for a master plumber's license or a journeyman plumber's license shall be conducted yearly during the months of February, May, August, and November.
- (b) A special examination may be conducted during other times of a year as the department directs.
- (c) Notice of the time and place of examination shall be given by the department at least one (1) week prior to the date of examination to each person who has a registration form on file, approved in accordance with subsection (1) of this section.

(4) Examination retakes. Within one (1) year from the date of the applicant's first notice of examination:

- (a) An applicant who fails to attend or successfully complete an examination for which he has been scheduled may request to reschedule or retake the examination. Except for the examination fee, an applicant shall not resubmit the requirements in subsection 1 of this section.

- (b) An applicant for a journeyman plumber's license who passes the written portion, the drawing portion, or the practical portion of the examination, but not all portions, may apply to retake only the portion failed.
 - (c) An applicant for a journeyman plumber's license who failed to achieve a passing score on the retaken portion of the examination may apply to retake the failed portion of the examination.
 - (d) An applicant shall pay the full examination fee for a retake of any portion of the examination.
- (5) A passing score on an examination shall be valid for three (3) years.

Section 2. Master Plumber License Application. To qualify for licensure as a master plumber, an applicant shall:

- (1)
 - (a) Have held a valid journeyman plumber's license for a minimum of two (2) years within the past five (5) years immediately preceding application and be actively employed in plumbing under the supervision of a licensed master plumber for a minimum of two (2) years;
 - (b) Hold an engineer license in Kentucky and be sufficiently experienced in mechanical engineering, as determined by the department based upon the number and complexity of the applicant's past mechanical engineer projects;
 - (c) Hold a valid plumbing license issued by another state for a minimum of two (2) years within the past five (5) years immediately preceding application; or
 - (d) Have been engaged in the practice of plumbing in another state that does not issue a plumbing license, in a capacity equivalent to a master plumber, for a minimum of four (4) consecutive years immediately preceding application.
- (2) Master plumber license application.
 - (a) An applicant for a master plumber license shall submit to the department:
 - 1. A completed Application for License as a Master Plumber, Form PLB-1;
 - 2. Proof of successfully completing the Kentucky master plumber examination with a passing score of a minimum of eighty (80) percent obtained for each portion of the examination; and
 - 3. A license fee of \$250.
 - (b) A master plumbing license applicant applying with experience under subsection (1)(c) or (d) of this section shall submit proof of successfully completing the journeyman plumber examination pursuant to Section 3(2)(b) of this administrative regulation.
- (3) The initial license fee for a master plumber may be prorated for not less than seven (7) months or more than eighteen (18) months and shall expire on the final day of the applicant's birth month.

Section 3. Journeyman Plumber License Application. To qualify for licensure as a journeyman plumber, an applicant shall:

- (1)
 - (a) Have At least two (2) consecutive years of experience as an apprentice plumber; or
 - (b) Complete a department approved course that includes content on the practice of plumbing or the Kentucky State Plumbing Code and at least one (1) year of experience as an apprentice plumber.
- (2) Journeyman plumber license application. An applicant for a journeyman plumber license shall submit to the department:
 - (a) A completed Application for License as a Journeyman Plumber, Form PLB-2;
 - (b) Proof of successfully completing the Kentucky journeyman plumber examination with a passing score of a minimum of seventy five (75) percent obtained for each portion of the examination; and
 - (c) A license fee of sixty (60) dollars.
- (3) The initial license fee for a journeyman plumber may be prorated for not less than seven (7) months or more than eighteen (18) months and shall expire on the final day of the applicant's birth month.

Section 4. License Renewals. (1) Filing for renewal. A master plumber and a journeyman plumber shall submit to the department:

- (a) The applicable renewal fee made payable to the Kentucky State Treasurer of:
 - 1. \$250 for a master plumber; or
 - 2. Sixty (60) dollars for a journeyman plumber;
- (b) Proof of completing the continuing education requirements established in 815 KAR 2:010; and
- (c) Proof of insurance as required by KRS 318.030 for a master plumber.

(2) Inactive status.

- (a) To place a plumbing license in inactive status:
 - 1. A master plumber shall pay an initial inactive fee of \$125.
 - 2. A journeyman plumber shall pay an initial inactive fee of thirty (30) dollars.
- (b)
 - 1. An inactive master plumber shall not secure a plumbing permit, advertise, represent himself as a qualified master plumber, or otherwise engage in the work of a master plumber.
 - 2. An inactive journeyman plumber shall not represent himself as a qualified journeyman plumber or otherwise engage in the work of a journeyman plumber.
- (c) To reactivate a plumbing license, the inactive licensed plumber shall complete all renewal requirements of subsection (1) of this section and pay the appropriate reactivation fee:
 - 1. \$125 for a master plumber; or
 - 2. Thirty (30) dollars for a journeyman plumber.

Section 5. Change of information. (1) A licensee shall notify the department of any change to the name or address of the business or employer.

(2) Death of a master plumber.

- (a) If the master plumber representing a company dies, the company shall notify the department within ten (10) days of the master plumber's death.
- (b) The 180 day interim period established in KRS 318.054 shall begin on the date the master plumber dies.
- (c) The company shall not be required to renew the deceased's master plumber license, if the license renewal date falls within the 180 day interim period.
- (d) The company shall not use the deceased master plumber's license after the expiration date of the interim period.
- (e) The company shall notify the department when the company has a replacement master plumber to represent the company.

Section 6. Incorporation by Reference. (1) The following material is incorporated by reference:

- (a) "Application for License as a Master Plumber", Form PLB-1, October 2019;
- (b) "Application for License as a Journeyman Plumber", Form PLB-2, October 2019; and
- (c) "Plumbing Examination Registration Form, Form PLB-3, October 2019.

(2) This material may be inspected, copied, or obtained, subject to applicable copyright law, at the Department of Housing, Buildings and Construction, Division of Plumbing, 500 Mero Street, Frankfort, Kentucky 40601-5412, Monday through Friday, 8 a.m. to 4:30 p.m. and is available online at <http://dhbc.ky.gov>. (1 Ky.R. 756; 1348; eff. 6-11-1978; 2 Ky.R. eff. 4-14-1976; 3 Ky.R. 237; eff. 11-3-1976; Recodified from 401 KAR 1:015, 7-5-1978; 7 Ky.R. 844; eff. 4-15-1982; 12 Ky.R. 1899; eff. 7-2-1986; 13 Ky.R. 956; eff. 12-2-1986; 17 Ky.R. 2878; eff. 5-3-1991; 3521; 18 Ky.R. 283; eff. 7-30-1991; 3037; 5-28-1992; 21 Ky.R. 1388; eff. 1-9-1995; 25 Ky.R. 2467; 2902; eff. 5-26-1999; 27 Ky.R. 3374; eff. 8-15-2001; 32 Ky.R. 2361; 33 Ky.R. 403; eff. 8-10-2006; 34 Ky.R.1237; 1747; eff. 2-1-2008; 37 Ky.R. 2757; 38 Ky.R. 20; eff. 8-5-2011; 41 Ky.R. 1199; 1795; eff. 3-6-2015; 45 Ky.R. 808; 1544; eff. 1-4-2019; 46 Ky.R. 1648, 2418; eff. 6-2-2020.)

815 KAR 20:050. Installation permits.

RELATES TO: KRS 318.030, 318.134, 318.160

STATUTORY AUTHORITY: KRS 198B.040(10), 318.130, 318.134(3)

NECESSITY, FUNCTION, AND CONFORMITY: KRS 318.130 requires the department to promulgate administrative regulations establishing the Kentucky State Plumbing Code to regulate plumbing. KRS 318.134(1) requires all persons, firms, or corporations to procure a plumbing installation permit from the department to construct, install, or alter, or cause to be constructed, installed, or altered any plumbing. KRS 318.134(3) requires the department to establish a reasonable schedule of fees and charges to be paid for plumbing installation permits and the necessary inspections incident thereto. This administrative regulation establishes the requirements, fees, and charges for plumbing installation permits and inspections in Kentucky.

Section 1. Permit Required. (1) A plumbing permit shall be required for:

- (a) A new plumbing installation;
 - (b) An existing plumbing installation if a fixture, soil, or waste opening or conductor is to be moved or relocated;
 - (c) A new house sewer or a house sewer that is to be replaced;
 - (d) A new water service or a water service that is to be replaced;
 - (e) The addition of a backflow prevention device to an existing water service; or
 - (f) A new water heater installation or a water heater that is to be replaced.
- (2) A new plumbing permit shall be required when a master plumber:
- (a) Takes over a plumbing installation originally permitted to another master plumber or homeowner; or
 - (b) Assumes responsibility to correct and test an installation made by someone else.
- (3) A permit shall not be required for:
- (a) The repair of:
 - 1. Leaks;
 - 2. Cocks; or
 - 3. Valves; or
 - (b) Cleaning out waste or sewer pipes.

Section 2. Issuance of Plumbing Permits. (1) A permit to construct, install, or alter plumbing, sewerage, or drainage shall be issued only to:

- (a) A licensed master plumber; or
 - (b) A homeowner who wishes to construct, install, or alter plumbing, sewerage, or drainage in a home occupied by the homeowner or constructed by the homeowner for the homeowner's own personal residential use, if:
 - 1. Application is made for the permit prior to the beginning of the work;
 - 2. The homeowner files with the application an affidavit stating that the homeowner shall abide by the terms of this section;
 - 3. All work shall be performed in compliance with 815 KAR Chapter 20;
 - 4. All the work shall be personally performed by the homeowner; and
 - 5. The homeowner shall not have obtained another homeowner permit for construction of a new home issued within the last five (5) years.
- (2) A journeyman plumber shall not construct, install, or alter plumbing, sewerage, or drainage unless the work is performed under the supervision of a licensed master plumber with a valid permit.

Section 3. Plumbing Plan Submission. (1) Procedure. Except as provided in subsection (2) of this section, plumbing plans shall be submitted to the department for review and approval prior to the issuance of a plumbing permit. A plumbing plan submission shall consist of:

- (a) A complete Plan Application form; and
- (b) Three (3) sets of identical plans that include:
 - 1. A complete floor plan;
 - 2. An isometric plumbing diagram of the drain, waste, and vent system; and
 - 3. A site utility plan.

(2) Field inspections. A plumbing inspector may inspect the plumbing in the following without an initial submission of plumbing plans:

- (a) An existing building if:
 - 1. There are no more than ten (10) openings for plumbing fixtures or appliances, present and future;
 - 2. There is no change of use in the occupancy;
 - 3. There is no increase in the occupant load;
 - 4. Approval by the Department of Health is not required; and
 - 5. Plans or documents of the installation are submitted to the department after installation;or
- (b) A multi-family dwelling if:
 - 1. The building consists of twelve (12) units or less;
 - 2. The water and sewer connections have been approved by the Division of Water in accordance with 401 KAR Chapter 5;
 - 3. Proof of a building permit from the authority having jurisdiction has been submitted to the department; and
 - 4. Plumbing plans are made available to the plumbing inspector for review and approval prior to construction.
- (c) A plumbing inspector shall not review and approve plans for the following:
 - 1. A tenant space that has not been occupied;
 - 2. A day care facility that is not currently licensed;
 - 3. A project on a private water system without approval from the Division of Water in accordance with 401 KAR Chapter 5; or
 - 4. A project with a sewer main extension or a sewage treatment plant without approval from the Division of Water in accordance with 401 KAR Chapter 5.

Section 4. Plumbing Permit Fees. (1) The base fee for each plumbing permit for residential one (1) and two (2) family units shall be forty-five (45) dollars plus seven (7) dollars for each:

- (a) Plumbing fixture, appliance, or opening left for a plumbing fixture or appliance in the soil or waste pipe system;
- (b) Domestic water heater; and
- (c) Separately metered water and sewer service if more than one (1) water or sewer service is to be installed.

(2) The base fee for each plumbing permit for buildings other than residential one (1) and two (2) family units shall be forty-five (45) dollars plus fifteen (15) dollars for each:

- (a) Plumbing fixture, appliance, or opening left for a plumbing fixture or appliance in the soil or waste pipe system;
- (b) Domestic water heater;
- (c) Conductor opening; and
- (d) Separately metered water and sewer service if more than one (1) water or sewer service is to be installed.

- (3)
 - (a) If only one (1) new domestic water heater is installed or replaced within a single building, the only fee for the plumbing permit shall be forty-five (45) dollars.
 - (b) If more than one (1) water heater is replaced within a building, a permit fee shall be calculated pursuant to subsections (1) or (2) of this section.
- (4) The plumbing permit fee shall be limited to the base fee if:
 - (a) The work to be performed does not include new installation;
 - (b) The work to be performed is to make corrections to or provide testing for an installation made by someone else; or
 - (c) A master plumber takes over a plumbing permit pursuant to Section 1(2).

Section 5. Inspection Fees. (1) A person with a plumbing permit shall be entitled to five (5) plumbing inspections at no additional cost.

- (2)
 - (a) The fee for an additional inspection shall be fifty (50) dollars.
 - (b) All additional inspection fees shall be paid prior to the final inspection.
- (3) Additional inspection fees shall not apply if the cost of the plumbing permit exceeds \$200.

Section 6. Expiration of Permits. (1) Plumbing permits issued pursuant to this administrative regulation shall expire one (1) year after the date of issuance unless construction is ongoing, in which case the permit shall remain effective until completion of the planned plumbing inspection.

- (2) The permit shall expire and become void if the plumbing work ceases on the project for a period exceeding twelve (12) months.

Section 7. Incorporation by Reference. (1) "Plan Application Form", 2/2020, is incorporated by reference.

- (2) This material may be inspected, copied, or obtained, subject to applicable copyright law, at the Department of Housing, Buildings and Construction, Division of Plumbing, 500 Mero Street, Frankfort, Kentucky 40601-5412, Monday through Friday, 8 a.m. to 4:30 p.m. and is available online at <http://dhbc.ky.gov>. (Recodified from 401 KAR 1:030, 7-5-1978; Am. 5 Ky.R. 160; eff. 10-4-78; 6 Ky.R. 696; 7 Ky.R. 220; eff. 10-1-80; 845; eff. 10-7-81; 9 Ky.R. 832; 1200; eff. 4-6-83; 13 Ky.R. 958; eff. 12-2-86; 17 Ky.R. 2880; eff. 5-3-91; 18 Ky.R. 1231; 1887; eff. 12- 8-91; 19 Ky.R. 2335; eff. 6-7-93; 21 Ky.R. 1389; eff. 1-9-95; 27 Ky.R. 3376; eff. 8-15-2001; 32 Ky.R. 2362; 33 Ky.R. 404; eff. 9-1-2006; 36 Ky.R. 1134; 2067-M; eff. 6-4-2010; 41 Ky.R. 167; eff. 9-24-2014; 1202; eff. 3-6-2015; 46 Ky.R. 1651, 2420; eff. 6-2-2020.)

815 KAR 20:055. Water heating devices.

RELATES TO: KRS Chapter 236, 318.200

STATUTORY AUTHORITY: KRS 198B.040(10), 318.130, 318.200

NECESSITY, FUNCTION, AND CONFORMITY: KRS 318.130 requires the department to promulgate administrative regulations establishing the Kentucky State Plumbing Code to regulate plumbing. KRS 318.200 requires that all retailers, wholesalers, and installers selling or offering for sale water heating devices, within thirty (30) days of the date of sale, forward a list of names and addresses of purchasers along with the serial number of the device purchased to the department or to the appropriate agency of county or city government having jurisdiction. This administrative regulation establishes the requirements for water heating devices.

Section 1. Installation requirements.

(1) General requirements.

(a) A water heater shall be:

1. Properly connected to the hot and cold water supply; and
2. Accessible for inspection, repair, and replacement.

(b) Temperature and pressure relief valves shall be installed in accordance with manufacturer's requirements.

(2) A water heater designed for use as an appliance for supplying potable hot water for domestic or commercial purposes may be used for space heating if the water temperature does not exceed 140 degrees Fahrenheit.

(3) Crawl Space.

(a) A water heater installed in a crawl space shall:

1. Have adequate access with a travel path no less than five (5) feet of vertical distance; and
2. Be installed on at least a two (2) inch thick corrosion resistant material adequate to support the water heater.

(b) The replacement of a water heater that was originally installed in a crawl space prior to September 1, 2006 shall be exempt from vertical distance requirement in paragraph (a)1. of this subsection.

(4) Attic, Drop Ceiling, or Wood Flooring.

(a) After April 1, 2021, a water heater installed in an attic, above a drop ceiling, or on wood flooring in the occupied space of a building shall be:

1. Installed with a corrosion resistant water tight pan below the water heater; and
2. Equipped with at least a three-fourths (3/4) inch drain to be piped similarly to a temperature and pressure relief valve discharge line.

(b) A temperature and pressure relief valve may discharge into the drain pan if the drain pan pipe:

1. Is equipped with a one (1) inch drain;
2. Is of a material suitable for hot water; and
3. Discharges through an air gap to a sump basin, service sink, open receptacle, or other point of discharge approved by the division, in accordance with 815 KAR 20:130.

(5) Fuel-fired water heaters.

(a) A fuel-fired water heater shall be connected to a flue or a chimney. The flue or chimney shall:

1. Be of a size at least as large as required by the water heater manufacturer's instructions;
2. Extend two (2) feet above the roof of the building;
3. Be properly flashed; and
4. Not terminate within six (6) feet of a door or window.

(b) A fuel-fired water heater vent shall not be connected to a flue serving a coal-burning apparatus.

(c) A fuel-fired water heater shall not be placed in any bathroom, toilet room, or a room used for sleeping unless it has a direct-vent or through the wall vent system.

(d) A fuel-fired water heater shall not be placed in a closed room or closet unless the space:

1. Has a louver door; or

2. Is ventilated to provide combustion air and circulation that satisfies the requirements of the National Fuel Gas Code in Chapter 35 of the Kentucky Building Code incorporated by reference in 815 KAR 7:120.

(6) Gas-fired direct vent water heaters.

(a) A residential gas-fired direct vent and through the wall type water heater shall be:

1. Vented in accordance with the manufacturer's instructions; and
2. Installed to satisfy the requirements of the National Fuel Gas Code in Chapter 35 of the Kentucky Building Code incorporated by reference in 815 KAR 7:120.

(b) 1. The vent terminal of a direct vent water heater with an input of 50,000 BTUs per hour or less shall be located at least nine (9) inches from any opening through which flue gases may enter the building.

2. The vent terminal of a direct vent water heater with an input over 50,000 BTUs per hour shall be located at least twelve (12) inches from any opening through which flue gases may enter the building.

(c) The bottom of the vent terminal and the air intake of a direct vent water heater shall be located at least twelve (12) inches above grade.

(7) Instantaneous water heaters. An instantaneous water heater not listed in 815 KAR 20:020 shall:

(a) 1. Be certified to ANSI Z21.10.

- 1 for units including but not exceeding 75,000 BTUs; or
2. Be certified to ANSI Z21.10.3 for units exceeding 75,000 BTUs;

(b) Have a minimum of three-fourths (3/4) inch inlet and outlet;

(c) Be installed with a properly sized pressure relief valve not exceeding 150 pounds per square inch; and

(d) Be installed to enable flushing without altering the installation, if required by the manufacturer to be periodically flushed.

Section 2. Water heaters subject to additional requirements. Water heaters shall be considered pressure vessels and shall comply with KRS Chapter 236 and 815 KAR Chapter 15 if the water heater exceeds:

- (1) Heat input of two hundred thousand (200,000) BTU/Hr.;
- (2) Water temperature of two hundred ten (210) degrees Fahrenheit; or
- (3) Water storage capacity of one hundred twenty (120) gallons.

Section 3. Domestic Solar Water Heaters.

A domestic solar water heater may have a "single wall heat exchanger" if:

(1) The solar panel and the water heater exchanger use a nontoxic liquid such as propylene glycol or an equivalent;

(2) The heat exchanger is pretested by the manufacturer to 450 pounds per square inch;

(3) The water heater has a warning label advising that a nontoxic heat exchanger fluid shall be used at all times; and

(4) A pressure relief valve is installed at the highest point in the solar panel.

Section 4. Domestic Water Heater Preheating Device.

(1) A domestic water heater preheating device may be used and connected with the high pressure line from the compressor of a domestic home air conditioner or heat pump heater.

(2) Double wall heat-exchangers with two (2) separate thicknesses separating the heat exchange fluid (other than potable water) from the potable water supply shall be provided.

(3) (a) The water inlet to the heat exchange vessel shall be provided with a check valve. A pressure relief valve, approved in accordance with this administrative regulation, set to relieve at five (5) pounds per square inch above the maximum water pressure at the point of installation shall be provided adjacent to and at the outlet side of the check valve, if the heat exchange units contain more than twenty (20) pounds of refrigerants.

(b) This device shall be equipped with a temperature limit control that would actuate a pump that would circulate hot water from the water heater through the pre-heater device.

- (4) (a) Condensate drain water shall be piped in accordance to the Kentucky Plumbing Code and shall not:
 - 1. Drain into a crawl space, sewer, or vent stack; or
 - 2. Be installed in an area subject to freezing.
- (b) A condensate pump shall be used if a drain is:
 - 1. Not available; or
 - 2. Located above the vent.

Section 5. Temperature and Pressure Relief Devices.

- (1) Only temperature and pressure relief devices approved by the department as established in 815 KAR 20:020 and 815 KAR 20:120 shall be installed.
- (2) A temperature and pressure relief device shall be installed:
 - (a) On each water heater on the hot water side not more than three (3) inches from the top of the water heater; and
 - (b) According to the manufacturer's recommendation, if a marked opening is provided on the water heater by the manufacturer for a temperature and pressure relief device.
- (3) (a) In a location with a floor drain, the discharge from the relief device shall be piped to within two (2) inches of the floor.
 - (b) In a location without a floor drain, the discharge from the relief device shall be piped to the outside of the building with an ell turned down and piped to within four (4) inches of the surface of the ground.
- (4) The relief device may discharge through an air gap to a sump basin, service sink, open receptacle, or other point of discharge in which equivalent safety shall be provided as approved by the department.

Section 6. Water Distribution for Fan Coil Units.

- (1) If a domestic water heater is used for heating purposes through a fan coil medium, the water temperature shall not exceed 140 degrees Fahrenheit.
- (2) The fan coil unit shall use not less than three-fourths (3/4) inch piping and its run shall not exceed 140 feet between the water heater and the heating unit.
- (3) The applicable requirements established in 815 KAR 20:070 shall be met.

Section 7. Reporting Requirements.

- (1) Except as established in subsection (2) of this section, a wholesaler, retailer, or installer who sells a water heating device shall submit to the division Form PLB-94, Water Heater Report Form, within thirty (30) days of the date of sale.
- (2) An installing contractor who obtains an installation permit for the installation of a water heating device shall be exempt from the reporting requirements of subsection (1) of this section. The installation permit shall serve as the reporting requirement for the installer as required by KRS 318.200.

Section 8. Incorporation by Reference.

- (1) Form PLB-94, "Water Heater Report Form", October 2019, is incorporated by reference.
- (2) This material may be inspected, copied, or obtained, subject to applicable copyright law, at the Department of Housing, Buildings and Construction, Division of Plumbing, 500 Mero St., Frankfort, Kentucky 40601-5412, Monday through Friday, 8 a.m. to 4:30 p.m. and is available online at <http://dhbc.ky.gov/Pages/default.aspx>. (11 Ky.R. 911; 1258; eff. 2-12-1985; 17 Ky.R. 2881; eff. 5-3-1991; 24 Ky.R. 2463; eff. 7-13-1998; 32 Ky.R. 2364; 33 Ky.R. 406; eff. 9-1-2006; 36 Ky.R. 1533; 2068-M; eff. 4-2-2010; 46 Ky.R. 1654, 2286, 2422; eff. 6-2-2020.)

815 KAR 20:060. Quality, weight, installation, and storage of materials.

RELATES TO: KRS 318.130, 318.150, 42 U.S.C. 300g-6

STATUTORY AUTHORITY: KRS 198B.040(10), 318.130

NECESSITY, FUNCTION, AND CONFORMITY: KRS 318.130 requires the department to promulgate administrative regulations establishing the Kentucky State Plumbing Code to regulate plumbing, including the quality, weight, installation, and storage of material. This administrative regulation establishes the manufacturer's specification number for the quality and weight of material that shall be used in the installation of plumbing systems and establishes minimum specifications for the intended use. This administrative regulation also establishes the minimum requirements for the storage and installation material used in the installation of plumbing systems.

Section 1. Quality and Handling of Materials. (1) The material used in a drainage or plumbing system or part of a system shall be free of defects and shall be handled as to not cause damage to the material.

(2) All pipes and fittings shall be:

- (a) Inspected for cracks or other damage prior to installation; and
- (b) Installed in compliance with the manufacturer's recommendations unless otherwise stated in 815 KAR Chapter 20.

Section 2. Storage. (1) Schedule 40 or 80 PVC and ABS.

(a) Pipe shall remain in lifts until ready for use. Lifts shall not be stacked more than three (3) high and shall always be stacked wood-on-wood. Loose pipe shall be stored in racks with a minimum support space of three (3) feet. Pipe shall be shaded but not directly covered if stored outside in high ambient temperatures to provide for free circulation of air and reduce the heat buildup due to direct sunlight exposure.

(b) Fittings shall be stored in their original cartons to remain free of dirt and to reduce the possibility of damage. As a best practice, fittings shall be stored indoors.

(2) CPVC, SDR 11.

(a) CPVC pipe, tubing, and fittings shall be stored under cover to avoid unnecessary dirt accumulation and long-term exposure to sunlight. Pipe and tubing shall be stored with continuous support in straight, uncrossed bundles.

(3) PEX. PEX shall not be stored where it will be:

- (a) Exposed to direct or indirect ultraviolet light (sunlight);
- (b) Exposed to materials that affect the basic properties of PEX, brass, or copper; or
- (c) Come into contact with chemicals, pipe thread compounds, putty, and mineral or linseed oil compounds.

(4) Solvent cement and primers. Solvent cement and primers shall not be exposed to ignition, sparks, open flames, or heat during storage and shall not be used beyond their marked shelf life.

Section 3. Marking. Each length of pipe, fitting, trap, fixture, or device used in a plumbing or drainage system shall be indelibly marked with the:

- (1) Weight or quality; and
- (2) Maker's mark or name (manufacturer's specification number).

Section 4. Vitrified clay pipe, concrete pipe, truss pipe, and SDR 35 pipe shall be produced, labeled, and used only as established in subsections (1) through (4) of this section.

(1) Vitrified clay pipe shall be as established in ASTM C700, and fittings ASTM C425.

(2) Concrete pipe shall be as established in ASTM C14, and fittings ASTM C443.

(3) Truss pipe shall be as established in ASTM D2680, unless it is solid wall truss pipe, which shall be as established in ASTM D2751.

- (4) Extra heavy SDR 35 sewer piping shall be as established in ASTM D3034.
- (5) Joints. Joints in pipe and fittings with no more than two (2) pipe sizes between vitrified clay, ABS, or PVC to cast iron pipe and fittings or the joining of either material may be made with the proper fittings by using a dispersion grade PVC ring produced and labeled as ASTM C443, C425, or C564, or an elastomeric PVC coupling.

Section 5. Cast iron Pipe. (Hub and Spigot and No-hub). (1) Extra heavy. Extra heavy cast- iron pipe and fittings shall be produced and labeled as ASTM A74.

(2) Service-weight. Service-weight cast iron pipe and fittings shall be produced and labeled as ASTM A74 and C1540.

(3) No-hub cast-iron and fittings shall be produced and labeled ASTM 888 or CISPI 301.

(4) No-hub couplings shall be produced and labeled as ASTM C1277, C564, C1563, or CISPI 310.

(5) Coating. Cast-iron pipe and fittings for underground use shall be coated with:

- (a) Asphaltum;
- (b) Coal tar pitch; or
- (c) A coating produced and labeled as ASTM A743.

(6) Instructions for Cutting Cast Iron Soil Pipe. During installation assembly, pipe and fittings shall be inserted into the hub or into the gasket firmly and seated against the bottom of the hub or against the center rib or shoulder of the gasket. To provide a sound joint with field cut lengths of pipe, ends shall be cut square and as smooth as possible with a metal cutting saw or snap type cutters.

(7) General Installation Instructions for Cast Iron Pipe.

(a) Vertical piping.

1. Vertical piping shall be secured at sufficiently close intervals to maintain alignment and to support the weight of the pipe and its contents. Approved metal clamps or hangers shall be used to support stacks at their bases and at sufficient floor intervals to meet the requirements of local codes.

2. If vertical piping is to stand free of any support or if no structural element is available for support and stability during construction, the piping shall be secured in its proper position by means of adequate stakes or braces fastened to the pipe.

(b) Horizontal piping, suspended.

1. Ordinary horizontal piping and fittings shall be secured at sufficiently close intervals to maintain alignment and prevent sagging or grade reversal. Each length of pipe shall be supported by a hanger located not more than eighteen (18) inches from the joint.

2. Terminal ends of all horizontal runs or branches and each change of direction or alignment shall be supported by a hanger.

3. Closet bends installed above ground shall be firmly secured.

(c) Horizontal piping, underground.

1. If trenches are dug too deep, the piping shall be supported with approved grillage laid on firm ground as established in 815 KAR 20:130. To maintain proper alignment during backfilling, the pipe shall be stabilized in proper position by partial backfilling and cradling.

2. Piping laid on grade shall be adequately secured to prevent misalignment when the slab is poured.

3. Closet bends installed under slabs shall be adequately secured.

(d) Joints.

1. Joints in cast iron shall either be caulked, screwed, or made with the use of neoprene gaskets. Neoprene gaskets shall be produced and labeled as ASTM C564.

2. Steel, brass, and copper joints connected to cast iron pipe shall be either screwed or caulked joints. Caulked joints shall be made by the use of a caulking spigot.

3. Cast iron coupling for joining hubless cast iron pipe shall consist of a neoprene gasket, cast iron clamps produced and labeled as ASTM A48, and stainless steel bolts and nuts produced and labeled as ANSI B 18.2.1 and ANSI B 18.2.2.

4. Lead and Oakum Joint Installation.
 - a. Insert the spigot into the properly cleaned hub.
 - b. An oakum strand shall be inserted into the joint which is of a diameter that can be pressed into the joint by hand and sufficiently long to make three (3) turns around the pipe. Drive the strand of oakum to the bottom of the joint using a yarning iron. Pack the oakum solidly and evenly using a packing iron and hammer.
 - c. Place additional strands of oakum into the joint until it fills the hub to within one-half (1/2) inch of the top, and using a packing iron and hammer, pack this oakum until it forms a uniform surface one (1) inch from the top of the hub.
 - d. Pour molten lead into the joint at one (1) spot between the hub and spigot until it arches up slightly above the top of the hub.
 - e. When the lead has cooled, drive it down at four (4) points around the hub using a caulking iron to insure uniform caulking.
 - f. Caulk the joint on the inside and outside edges using a sixteen (16) ounce ball peen hammer and appropriate caulking irons.
5. Compression Joint Installation.
 - a. Fold and insert the one (1) piece rubber gasket into the hub which has been properly cleaned.
 - b. Apply special gasket lubricant to the spigot and inside of the neoprene gasket.
 - c. Push, draw or drive the spigot into the gasketed hub with a pulling tool or suitable device.
6. No-hub Joint Installation.
 - a. Clamp and gasket installation. The following procedures shall be taken to insure a proper joint:
 - (i) Place the gasket on the end of one (1) pipe and the stainless steel or cast iron clamp assembly on the end of the other pipe.
 - (ii) Firmly seat the pipe ends against the integrally molded shoulder inside the neoprene gasket.
 - (iii) Slide the clamp assembly into position over the gasket and tighten the bands or clamps as described below.
 - b. Torqueing bands. A properly calibrated torque wrench, set at sixty (60) inch pounds shall be used. The following procedure for applying torque to the band assembly shall be used: The stainless steel bands shall be tightened alternately and firmly to sixty (60) inch pounds of torque.
 - (i) Step 1. The inner bands shall be tightened alternately and firmly to sixty (60) inch pounds of torque.
 - (ii) Step 2. The outer bands shall be tightened alternately and firmly to sixty (60) inch pounds of torque.
 - (iii) Torqueing clamps. A properly calibrated torque wrench, set at 175 inch pounds, shall be used. The following procedure for applying torque to the clamp assembly shall be used: The stainless steel bolts shall be tightened alternately, gradually, and firmly to 175 inch pounds torque.

Section 6. Steel and Wrought iron Pipe. (1) All wrought iron pipe shall be produced and labeled with the latest ASTM "specifications for welded wrought iron pipe".

(2) Steel pipe shall be produced and labeled with the current ASTM specification number for welded wrought iron pipe or welded and seamless pipe.

(3) Schedule 40 shall be the minimum weight.

(4) For water distribution or soil, waste and vent, galvanized pipe shall be used.

(5) Cutting and Reaming.

(a) Pipe shall be cut to length with a square cut using the appropriate tool.

- (b) If the cut-to-length pipe is to be threaded or prepared for a mechanical connection, it shall be reamed to the full inner diameter of the pipe.
- (6) Hangers and Supports.
- (a) Hangers, anchors and supports shall be:
1. Of sufficient strength to support the piping and its contents; and
 2. Securely attached to the building construction at intervals to support the piping and its contents and made to allow for expansion, contraction, structural settlement and vibration.
- (b) Vertical piping.
1. Screwed piping shall be supported at every other story height and supports shall be of ferrous metal.
 2. Mechanical joint piping shall be supported at every story height and supports shall be of ferrous metal.
- (c) Horizontal piping.
1. Horizontal piping shall be supported at intervals which keep the piping in alignment and prevent sagging.
 2. Screwed and mechanical joint pipe one and one-half (1 1/2) inches and over shall be supported at twelve (12) foot intervals. One and one-quarter (1 1/4) inch and smaller shall be supported at eight (8) foot intervals.
 3. Supports shall be of ferrous metal.
- (7) Joints.
- (a) Screw Joints.
1. Screw joints shall be made by the use of a properly cut thread inserted into the female part of the fitting after applying the recommended pipe joint compound sparingly to the male threads.
 2. The screw joints shall be tightened hand tight to check for alignment and then tightened enough to insure a tight leak-proof joint but shall not be over-tightened.
- (b) Mechanical joints.
1. Mechanical joints for hot and cold water shall not be used above ground unless the couplings are galvanized and the gaskets are ASTM D2000, Grade N-R-615 BZ.
 2. The pipe ends shall be lubricated with a lubricant in compliance with the manufacturer's instructions and the gasket shall be slipped over one (1) pipe end.
 3. The pipe ends shall be connected and the gasket shall be inserted into central spanning position.
 4. The housing clamps shall be placed over the gasket and the bolts and nuts tightened with a socket wrench.
- (c) Steel connections to cast iron pipe. Steel joints connected to cast iron pipe shall be either screwed or caulked joints.
- (d) PVC and ABS pipe and fitting connections to steel. 1. PVC and ABS pipe and fitting connections to steel shall be either a screwed or caulked joint.
- (e) Stainless steel tubing to cast iron pipe shall be made by caulking spigot.
- (f) Stainless steel tubing to galvanized steel pipe or copper pipe shall be made by the use of an adaptor.
- (g) The joints between lead pipe and steel or wrought iron shall be made by means of a caulking ferrule or a soldering nipple.

Section 7. Brass Pipe, Copper Pipe, Seamless Stainless Steel Tubing, and Brass Tubing. (1) Brass pipe, copper pipe, and brass tubing shall be produced and labeled with the latest specifications of ASTM for "brass pipe, copper pipe, and brass tubing, standard sizes".

(2) Cutting, reaming, and sizing. The tube shall be cut to exact length with a square cut using the appropriate tool.

(a) The tube shall have burrs and slivers removed by using a reamer or other appropriate tool.

(b) The tube shall be brought to true dimensions and roundness by using a sizing tool consisting of a plug and ring.

(3) Cleaning. The surface to be joined shall be clean and free from oil, grease and heavy oxides. The end of the tube shall be cleaned with a fine sand cloth or a special wire brush a distance slightly more than is required to enter the socket of the fitting.

(4) Hangers and Supports. Hangers, anchors and supports shall be:

(a) Of material of sufficient strength to support the piping and its contents; and

(b) Securely attached to the building construction at sufficiently close intervals to support the piping and its contents and made to allow for expansion, contraction, structural settlement, and vibrations.

(c) Vertical piping.

1. Copper tubing shall be supported:

a. At each story for piping one and one-half (1 1/2) inches and larger in diameter; and

b. At each story and not more than ten (10) foot intervals for piping one and one-quarter (1 1/4) inches and smaller in diameter.

2. Supports shall be of copper material of sufficient strength which will not adversely react with the piping material.

(d) Horizontal piping.

1. Copper tubing shall be supported at:

a. Six (6) foot intervals for one (1) inch and smaller in diameter; and

b. Ten (10) foot intervals for one and one-quarter (1 1/4) inch and larger.

2. Supports shall be of copper material of sufficient strength which will not adversely react with the piping material.

(5) Joints.

(a) Soldered joints. Joints of copper pipe, brass, and seamless stainless steel tubing shall be soldered. The following procedures shall be used to solder a joint:

1. After cleaning, the surfaces shall be covered with a thin film of mildly corrosive liquid or petroleum based pastes that contain chlorides of zinc and ammonium. Self-cleaning flux shall not be used in place of the cleaning pipe.

2. Excess flux shall be wiped off within the fitting socket.

3. The tube end shall be inserted into the socket, with the tube firmly seated against the end of the socket.

4. Excess flux shall be removed with a rag.

5. Heat shall be applied to the fitting and then moved in order to heat as large an area as possible. The fitting and joint shall:

a. Not be overheated; and

b. Be heated until the solder melts on contact with the pipe and flows by capillary attraction into the joint.

6. The heat shall be removed.

7. The fitting and joint shall be cooled before moving.

(b) Brazed joints. The following procedures shall be used for a brazed joint:

1. Except as provided in subparagraph 2 of this paragraph, after cleaning, the surface of the tube end and the fitting socket shall be covered with a thin film of flux in accordance with the recommendations of the manufacturer of the brazing filler metal being used. Effort shall be made to avoid getting flux inside the tube.

2. Flux may be omitted if joining copper tube to wrought copper fittings with copper-phosphorus alloys (B-cup Series) which are self-fluxing on copper.

3. The tube end shall be inserted into the socket hard against the stop and turn if possible.
 4. Heat shall be applied to the parts to be joined, with:
 - a. The tube heated first; and
 - b. The fitting at the base of the cup heated next.
 5. Brazing wire, rod or strip shall be applied at the point where the tube enters the socket of the fitting.
 6. The heat shall be removed.
 7. The fitting and joint shall be cooled.
- (c) Flared joints; impact tools. The following procedures shall be used for a flared joint.
1. The joints shall be cut, reamed, sized, and cleaned.
 2. The coupling nut shall be slipped over the end of the tube.
 3. The flaring tool shall:
 - a. Be inserted into the tube end; and
 - b. Be driven by hammer strokes to expand the end of the tube to the desired flare.
 4. The fitting shall be placed squarely against the flare.
 5. The coupling nut shall be engaged with the fitting threads.
 6. The joint shall be tightened with two (2) wrenches, one (1) on the nut and one (1) on the fitting.
- (d) Screw type flaring block.
1. The procedures established in subparagraphs 1. and 2. of paragraph (c), subsection (6) of this section shall be followed for impact flaring.
 2. The tube shall be clamped in the flaring block so that the tube is slightly above the block.
 3. The yoke of the flaring tool shall be placed on the block so that the beveled end of the compression cone is over the tube end.
 4. The compressor screw shall be turned down firmly, forming the flare between the chamber in the flaring block and the beveled compressor cone.
 5. The flaring tool shall be removed and assembled pursuant to subparagraphs 4., 5., and 6. of paragraph (c) of this section.
- (e) Mechanically formed tee connection.
1. A mechanically formed tee connection shall be approved for use in a domestic hot and cold water distribution system above ground only.
 2. A mechanically extracted collar shall be formed in a continuous operation consisting of drilling a pilot hole and drawing out the tube surface to form a collar having a height of not less than three (3) times the thickness of the tube wall. The collaring device shall be fully adjustable so to insure proper tolerance and complete uniformity of the joint.
 3. All joints shall be brazed in accordance with subsection (2) of this section and the manufacturer's instructions. A soldered joint shall not be permitted.
- (f) Mechanical couplings. Types K and L copper tubing systems from two (2) inch through six (6) inch and used for water distribution may be installed using mechanical pipe couplings of a bolted type with a flush seal gasket along with grooved end copper fittings. Couplings shall be of the angle pad design to obtain rigidity.

Section 8. Borosilicate Pipe, Stainless Steel Tubing, Silicon Iron Pipe, Polyethylene Pipe, and Polypropylene Pipe. (1) Borosilicate pipe. Borosilicate pipe shall be produced and labeled ASTM C1053 for drain, waste, and vent applications.

(2) Stainless steel tubing.

(a) Stainless steel tubing for hot and cold water piping shall be produced and labeled either as ASTM A269 or ASTM A312.

(b) Stainless steel tubing for the soil, waste, and vent system shall be 304 or 316L produced and labeled as ASME A112.3.1.

(3) PE pipe used in acid waste systems shall be produced and labeled as ASTM 1204.

(4) PP pipe used in acid waste systems shall be produced and labeled as ASTM D4101 or ASTM F1412.

(5) Joints.

(a) Stainless steel tubing to cast iron pipe shall be made by caulking spigot.

(b) Stainless steel tubing to galvanized steel pipe or copper pipe shall be made by the use of an adaptor.

(c) Joints in PE and PP piping shall be made by the heat fusion process.

(d) Joints in PP shall be made with a union joint.

(e) Joints in borosilicate pipe shall be a stainless steel mechanical joint.

(f) Joints between silicon iron pipe shall be either caulk joint or stainless steel mechanical joint.

Section 9. Schedule 40, ABS and PVC plastic pipe and fittings. (1) All plastic piping used in a drainage, waste, and vent system shall be:

(a) Schedule 40 or 80, Type 1, Grade 1, PVC produced and labeled as ASTM D1785;

(b) Cellular core PVC produced and labeled ASTM F891;

(c) Schedule 40 or 80 ABS produced and labeled as ASTM D2661; or

(d) Cellular core ABS produced and labeled as ASTM F628.

(2) Pipe and fittings shall be produced and labeled in accordance with the provisions of ASTM D2665, as amended, for PVC and ASTM D2661 for ABS, and both shall bear the National Sanitation Foundation seal of approval.

(3) All pipe and fittings shall bear the ASTM designation together with the NSF seal, the manufacturer's identification, and the size.

(4) (a) The use of plastic pipe and fittings (PVC or ABS) shall be limited to buildings in which the plumbing system does not exceed forty-five (45) feet in height, measured from the grade plane, and continuing through the vertical distance of the building to a maximum height of forty-five (45) feet, unless:

(b) The use of PVC and ABS piping is limited to schedule 40 or 80 produced and labeled as ASTM D2665 and ASTM D1785 for PVC piping and ASTM D2661 for ABS piping;

(c) The installation of the plastic pipe and fittings (PVC or ABS) is made in compliance with the manufacturer's recommendations, which shall be made available to the inspector; and

(d) Firestop systems are inspected in accordance with ASTM E2174 by an approved inspection agency.

(5) Installation.

(a) Underneath concrete floors. Pipe and fittings shall be laid on stable earth conditions and have four (4) inches of grillage on its bottom, top and sides. If ground is unstable, it shall be removed and the excavation filled with grillage to the underneath side of the piping. Soil or waste pipe shall not be placed in a concrete slab except those pipes that pass vertically through it.

(b) Above concrete floors. Horizontal piping shall be properly aligned and installed without strain. Piping shall not be bent or pulled in position either before or after solvent welds have been made. It shall be supported at intervals not to exceed four (4) feet and at the end of the branches and at the change of direction and shall be so installed as to permit freedom of movement. Vertical piping shall be supported at their bases and all upward movement shall not be restricted. Closet flanges shall be securely fastened to the floor through which it passes.

- (6) Hangers. Hangers and straps shall be at least one (1) inch wide and shall not compress, distort, cut, or abrade the piping to allow free movement at all times.
- (7) Joints.
- (a) Joints in PVC Schedule 40 or 80 pipe and fittings shall be solvent welded joints and shall be in compliance with ASTM D2665.
 - (b) Joints in ABS pipe and fittings shall be solvent welded joints and shall be in compliance with ASTM D2661.
 - (c) ABS and PVC sewer piping produced and labeled as ASTM 3034 shall be joined by solvent cement in compliance with the applicable standard or with an elastomeric joint in compliance with ASTM D3212.
 - (d) Piping shall be cut square with a saw or pipe cutter designed especially for plastic pipe. Pipe and fittings shall be protected from serrated holding devices or abrasions.
 - (e) Burrs shall be removed from both inside and outside of the pipe. Dust, dirt and moisture shall be removed from the surfaces that shall be cemented.
 - (f) Solvent chemical cleaner recommended by the company whose product is being installed shall be applied inside the fitting and on the outside of the piping shall be joined.
 - (g) A paint brush shall be used to apply the solvent cement in a moderate, even coating in the fitting socket as well as covering the pipe on the joining surfaces.
 - (h) Joints shall be assembled as quickly as possible before the cement dries. Insert the piping into the fitting socket turning the pipe slightly to ensure even distribution to the cement. Hold the piping in a firm position so it does not "back out" of the joint.
 - (i) Remove excess solvent cement from the exterior of the joint with a clean dry cloth. The joint shall not be handled for a two (2) minute period. A fifteen (15) minute period shall be allowed for the joint to develop hanging strength.
 - (j) A Cemented pipe joint shall not be made in conditions of excessive moisture (ninety (90) percent humidity level) or if the temperature is below forty (40) degrees or above ninety (90) degrees Fahrenheit.
 - (k) ABS and PVC pipe and fitting connections to steel, brass, copper, or cast iron pipe shall be either a screwed or caulked joint.
 - (l) Joints between Schedule 40 PVC or ABS pipe and cast iron pipe may be made by the use of a neoprene gasket produced and labeled as ASTM C564.
 - (m) Caulk joints shall be made with the use of either a PVC or ABS or cast iron caulking spigot.
- (8) Commingling of Plastic Pipe. Plastic pipe shall not be commingled except through the use of male and female adapters or other transition fittings approved in accordance with 815 KAR 20:020, Section 4.
- (9) Mixing of plastic and Metal Piping. Plastic and metal piping shall discharge into one another by the use of proper fittings and adapters.
- (10) Thermal Expansion. Each plumbing installation shall be engineered and designed giving due consideration to the expansion characteristics of the material. Expansion tables for both PVC and ABS schedule 40 plastic piping are as follows:

PVC-DWV TYPE 1 THERMAL EXPANSION TABLE							
Chart shows length change in inches vs. degrees temperature change							
Lg. Ft	40° F	50° F	60° F	70° F	80° F	90° F	100° F
20	.278	.348	.418	.487	.557	.626	.696
40	.557	.669	.835	.974	1.114	1.235	1.395
60	.835	1.044	1.253	1.462	1.670	1.879	2.088
80	1.134	1.392	1.672	1.949	2.227	2.506	2.784
100	1.392	1.740	2.088	2.436	2.784	3.132	3.480

ABS-DWV TYPE 1 THERMAL EXPANSION TABLE							
Chart shows length change in inches vs. degrees temperature change							
Lg. Ft	40° F	50° F	60° F	70° F	80° F	90° F	100° F
20	.536	.670	.80	.938	1.072	1.206	1.340
40	1.070	1.340	1.610	1.880	2.050	2.420	2.690
60	1.609	2.010	2.410	2.820	3.220	3.620	4.020
80	2.143	2.680	3.220	3.760	4.290	4.830	5.360
100	2.680	3.350	4.020	4.700	5.360	6.030	6.700

Section 10. SDR 11, CPVC plastic pipe and fittings. (1) Installation. Correct assembly shall consist of the following steps:

- (a) Cutting the pipe square;
- (b) Removing burrs;
- (c) Cleaning both pipe end and fitting socket with a CPVC cleaner in compliance with manufacturer's recommendations, unless using an approved one (1) step cement.
- (d) Applying a liberal coat of CPVC solvent cement to the pipe and applying a light coat of cement to the fitting socket, removing all excess cement from the interior which may clog the waterway;
- (e) Assembling immediately by bottoming the pipe in the socket and rotating one-quarter (1/4) turn as the joint is assembled.
- (f) Removing excess cement from the joint; and
- (g) Determining if the joint has been properly assembled by looking for a small bead of cement to appear at the junction between the pipe or tubing and the fitting.

(2) Installation Temperature. Extra care shall be taken if installing in temperatures below forty (40) degrees Fahrenheit or above 110 degrees Fahrenheit. The manufacturer's installation instructions shall be followed carefully.

(3) Hangers and Supports. Support shall be provided at each floor level for piping installed in vertical runs. For horizontal runs, support shall be provided at three (3) foot intervals for pipe one (1) inch or less in diameter and at four (4) foot intervals for larger pipe sizes. Piping shall not be anchored tightly to a support but secured with smooth straps or hangers allowing for movement caused by expansion and contraction. Hangers shall not have rough or sharp edges that come in contact with the piping.

(4) CPVC-to-metal Transitions. CPVC threaded adapters shall not be used to transition from CPVC to metal. Union type fittings that use gaskets or orings to seal dissimilar connections shall not be used. Compression type transition fittings, over-molded transition fittings and push-type fittings that meet the ASSE 1061 standard may be used.

(5) Thermal Expansion. The linear thermal expansion rate for CPVC is approximately one-half (1/2) inch for each ten (10) degrees Fahrenheit temperature change for each 100 feet of pipe or tubing. If installing long runs of pipe, one-sixteenth (1/16) to three thirty-seconds (3/32) inch longitudinal clearance shall be allowed per foot of run to accommodate thermal expansion. Offsets of twelve (12) inches or more every ten (10) feet shall be included on vertical risers if they are restrained by horizontal branches at each floor.

Section 11. PEX. (1) PEX that is to be used for cold water only shall be produced and labeled as established by ASTM F876.

(2) PEX that is to be used for either cold water or hot water shall be produced and labeled as established by ASTM F877.

(3) PEX-AI-PEX shall be produced and labeled as established by ASTM F1281.

(4) Cold expansion fittings with PEX reinforcing rings for use with PEX tubing shall be produced and labeled as established by ASTM F1960.

(5) Metal insert fittings utilizing a copper crimp ring shall be produced and labeled as established by ASTM F1807.

(6) Stainless steel clamps substituted for the copper crimp ring shall be produced as established by ASTM F2098.

(7) Plastic insert fittings for PEX shall be produced as established by ASTM F2159.

- (8) Push fit fittings for PEX shall be produced as established by ASSE 1061.
- (9) Metal insert fittings for PEX/aluminum/PEX composite pressure pipe shall be produced as established by ASTM F1974.
- (10) Metal insert fittings utilizing a copper crimp ring for PEX-AL-PEX shall be produced as established by ASTM F2434.
- (11) Installation.
- (a) Water service installation.
 - 1. Tubing shall be snaked in the ditch to allow for linear expansion and contraction.
 - 2. Tubing shall not be installed in contaminated soils.
 - 3. PEX shall not be installed in areas of known soil contamination or where there is a high risk of chemical spills such as organic solvents or petroleum distillates.
 - 4. Metallic fittings other than those consisting of red brass shall be protected from the soil to prevent corrosion.
 - 5. The number of fittings shall be kept to a minimum.
 - 6. The bottom of the trench shall be flat and free of rocks, hollows, or other sharp objects.
 - 7. If placed in soil consisting of rock, piping shall be covered with six (6) inches of coarse sand or pea gravel
 - 8. If passing through a foundation wall, a rigid sleeve that spans the distance from within the wall out to the undisturbed soil shall be used to prevent shearing of the tubing.
 - (b) Distribution system.
 - 1. If PEX is to be buried under a building, fittings shall not be used.
 - 2. PEX passing through a concrete slab or wall shall be protected by use of sleeves.
 - 3. PEX passing through metal studs or plates shall be protected by plastic grommets designed for this purpose.
 - 4. PEX shall not be used in operating conditions inconsistent with pressure ratings that appear on the tubing and the applicable ASTM standard.
 - 5. PEX shall not be installed:
 - a. Where it may be exposed to direct or indirect ultraviolet light (sunlight);
 - b. Where it may be exposed to open flame;
 - c. With or exposed to petroleum based caulking or sealants;
 - d. Where it may be subjected to prolonged exposure to free chlorine concentrations greater than four (4) ppm;
 - e. Within twelve (12) inches of any recessed light fixture; or
 - f. Within six (6) inches of any gas appliance metallic vent.
 - 6. PEX shall be tested under a pressure not to exceed 100 pounds per square inch nor less than forty (40) pounds per square inch.
- (12) Hangers and supports.
- (a) PEX sizes one (1) inch and smaller installed horizontally shall be supported at intervals not to exceed thirty-two (32) inches.
 - (b) PEX sizes 1-1/4" and larger installed horizontally shall be supported at intervals not to exceed forty-eight (48) inches.
 - (c) PEX installed vertically shall be supported at the base of each story with a mid-story guide.
 - (d) PEX shall not be rigidly anchored but shall be installed to allow room for proper expansion and contraction of the tubing.
 - (e) Hangers or strapping shall be constructed of plastic material or be coated to prevent damage to the tubing.
 - (f) PEX-Al-PEX installed horizontally shall be supported at intervals not to exceed ninety-eight (98) inches.
 - (g) PEX-Al-PEX installed vertically shall be supported at the base of each story with a mid-story guide.

Section 11. Lead Pipe. (1) Lead soil, waste, and vent pipe shall be produced and labeled as Federal Specifications WW-P-325 and shall not be lighter than the weights established in the following table:

Size Inside Diameter Inches	Commercial Designation "D" or "XL"		Wall Thickness Inches	Weight Pounds	Per Foot Ounces
1 1/2	D	XL	0.138	3	8
2	D	XL	0.142	4	12
3	D	XL	0.125	6	0
4	D	XL	0.125	8	0

(2) Lead bends and lead traps. All lead bends and lead traps shall be of the weight known as extra heavy (XH) and shall have at least one-eighth (1/8) inch wall thickness.

(3) Joints.

(a) Joints in lead pipe or between lead pipe and brass or copper pipes, ferrules, soldering nipples, or trap, shall be full-wiped joints with an exposed surface of the solder at each side of the joint of not less than three-quarters (3/4) of an inch.

(b) The minimum thickness of the thickest part of the joint shall be at least as thick as the material being used.

(c) If lead pipe is used for acid waste lines, the pipe may be joined by burning.

(d) The joints between lead to cast iron, steel, or wrought iron shall be made by means of a caulking ferrule or a soldering nipple.

Section 12. Unions. Unions shall be ground faced and shall not be concealed or enclosed.

Section 13. Integral Flashing and Roof Joints. (1) If a roofing system requires integral flashing, a flashing material, which is part of the manufactured roofing system and required by the roofing manufacturer to guarantee or warranty the roofing system, shall be used.

(2) The joint at the roof shall be made watertight by the use of copper, lead, or other approved flashing or flashing material.

(3) (a) Except as established in paragraph (b) of this subsection, the approved flashing shall:

1. Not extend less than six (6) inches from the pipe in all directions; and

2. Extend upward twelve (12) or more inches and turn down into the pipe.

(b) Lead flashings for three (3) inch and four (4) inch vent stacks shall have a minimum twelve (12) inch base.

(4) A hub flashing may be used if it is constructed in a manner allowing the flashing to be caulked into a hub above the roof.

Section 14. Wall or Floor Flange Joints. Wall or floor flange joints shall be made by using a lead ring or brass flange and shall be properly soldered.

Section 15. Sheet Lead. Sheet lead for a shower pan shall not weigh less than four (4) pounds per square foot and shall not weigh less than two and one-half (2 1/2) pounds per square foot for vent pipe flashings.

Section 16. Sheet Copper or Brass. Sheet copper or brass shall not be lighter than No.

18 B. & S. gauge, except local and interior ventilating pipe shall not be lighter than No. 26 B. & S. gauge.

Section 17. Threaded Fittings. (1) A plain screw fitting shall be either cast iron, malleable iron, or brass of standard weight and dimension.

(2) A drainage fitting shall be either cast iron, malleable iron, or brass, with smooth interior waterway, with threads tapped out of solid metal.

(3) A cast iron fitting used in a water supply distribution shall be galvanized.

(4) A malleable iron fitting shall be galvanized.

Section 18. Caulking Ferrules. A caulking ferrule shall be of red brass and shall be in accordance with the following table:

Pipe Sizes Inches	Inside Diameter Inches	Length Inches	Minimum Weight Each
2	2 1/4	2 1/2	1 lb. 0 oz.
3	3 1/4	4 1/2	1 lb. 12 oz.
4	4 1/4	4 1/2	2 lb. 8 oz.

Section 19. Soldering Nipples. A soldering nipple shall be recessed red cast brass, iron pipe size. If cast, they shall be full bore and of minimum weight.

Section 20. Increasesers and reducers. If different size pipes or fittings are to be concealed, the proper size increaser or reducer pitched at an angle of forty-five (45) degrees between the two (2) sizes shall be used. This section shall not apply to nonmetallic installations.

Section 21. Floor Flanges for Water Closets and Service Sinks or Similar Fixtures. (1) A floor flange shall either be:

- (a) Hard lead;
- (b) Brass;
- (c) Cast iron;
- (d) Galvanized malleable iron;
- (e) ABS; or
- (f) PVC.

(2) A hard lead or brass flange shall not be less than one-eighth (1/8) inch thick.

(3) Cast iron or galvanized malleable iron shall:

- (a) Not be less than one-fourth (1/4) inch thick; and
- (b) Have a two (2) inch caulking depth.

Section 22. Use of Lead. (1) Lead shall not be used in the installation or repair of a public or private water system providing potable water for human consumption.

(2) This section shall not apply to:

- (a) Pipes, pipe fittings, plumbing fittings, or fixtures, including backflow preventers, that are used exclusively for nonpotable services such as manufacturing, industrial processing, irrigation, outdoor watering, or any other uses in which the water is not anticipated to be used for human consumption; or
- (b) Toilets, bidets, urinals, fill valves, flushometer valves, tub fillers, shower valves, service saddles, or water distribution main gate valves that are two (2) inches in diameter or larger.

Section 23. Prohibited Joints and Connections. A fitting or connection that has an enlargement chamber, or recess with a ledge shoulder, or reduction of the pipe area in the direction of the flow shall be prohibited.

Section 24. New Materials. (1) Materials other than those established in this administrative regulation shall be prohibited unless the material is specifically approved by the division and the department as being equal to or better than the material specified in this code.

(2) It shall be the responsibility of any person or company seeking the approval of a material not included in this code to prove that the material is equal to or better than the material that it is intended to replace.

(3) Procedural requirements for approval of new parts and materials are established in 815 KAR 20:020. (Recodified from 401 KAR 1:030, 7-5-1978; Am. 5 Ky.R. 160; eff. 10-4-1978; 6 Ky.R. 133; 384; eff. 1-2-1980; 8 Ky.R. 359; eff. 1-6-1982; 14 Ky.R. 1123; eff. 1-4-1988; 15 Ky.R. 601; 970; eff. 9-28-1988; 17 Ky.R. 2882; eff. 5-3-1991; 18 Ky.R. 2720; eff. 4-3-1992; 19 Ky.R. 999; 1385; eff. 12-8-1992; 27 Ky.R. 1902; 2794; eff. 3-22-2001; TAm eff. 8-9-2007; 35 Ky.R. 2586; 36 Ky.R. 83; eff. 7-29-2009; 41 Ky.R. 169; eff. 9-24-2014; 42 Ky.R. 127; 1193; eff. 11-6-2015; 43 Ky.R. 621; eff. 1-6-2017; 46 Ky.R. 1657, 2424; eff. 6-2-2020.

815 KAR 20:070. Plumbing fixtures.

RELATES TO: KRS 318.010, 318.015, 318.150, 318.200

STATUTORY AUTHORITY: KRS 198B.040(10), 318.130

NECESSITY, FUNCTION, AND CONFORMITY: KRS 318.130 requires the department to promulgate an administrative regulation establishing the Kentucky State Plumbing Code regulating plumbing, including the kind, type, and quality of plumbing fixtures to be used in the construction of plumbing systems. This administrative regulation establishes the requirements for plumbing fixtures to be used in Kentucky.

Section 1. Materials. Receptacles used as water closets, urinals, or for the disposal of human excreta, shall be of vitrified earthenware, hard natural stone, or cast-iron with a light color porcelain enameled on the inside, except as established in Section 4 of this administrative regulation.

Section 2. Installation. (1) Plumbing fixtures shall be installed to allow access for cleaning.

(2) All pipes from fixtures shall be run to the wall.

(3) A trap or pipe shall not extend nearer to the floor than twelve (12) inches except laundry trays or similar fixtures.

Section 3. Water Closet Bowls. (1) A water closet bowl shall be of one (1) piece construction and hold a sufficient quantity of water when filled to the trap overflow to prevent fouling of its interior surfaces.

(2) A water closet bowl shall be provided with an integral flushing rim to flush the entire interior of the bowl.

Section 4. Plastic Water Closet Bowl and Tank. (1) A plastic water closet bowl and tank shall be constructed with a PP lining inside the one (1) piece bowl and tank.

(2) The outer surface of the bowl shall be constructed of PVC material.

(3) The filler material between the lining and outer surface shall be made of polyurethane foam.

(4) The bowl shall have:

(a) A three (3) inch water seal; and

(b) A two and one eighth (2 1/8) inch waste opening passage.

Section 5. Frost-proof Closet. (1) A frost-proof water closet may be installed only in a building that has at least a twelve (12) inch air break between it and any building used for habitation or occupancy.

(2) The frost-proof water closet room shall:

(a) Be tightly enclosed and accessible from the outside only;

(b) Have a nonabsorbent floor;

(c) Have a soil pipe between the trap and hopper of four (4) inches in diameter; and

(d) Have a four (4) inch vent.

Section 6. Floor and Shower Drains. (1) A floor drain or a shower drain shall be considered a plumbing fixture and shall be provided with a strainer.

(2) Shower drain pan construction.

(a) A shower drain pan shall be constructed to a minimum height of six (6) inches on all vertical walls. (b) A shower drain pan shall not be required on a concrete floor below the outside grade level.

(c) A shower drain pan shall be constructed of:

1. Sheet lead weighing not less than four (4) pounds per square foot;

2. Nonplasticized chlorinated polyethylene produced and labeled as ASTM D412 and D1204, which shall be not less than four hundredths (0.040) inches thick;
 3. Nonplasticized PVC sheet material produced and labeled as ASTM D1004, D412, D412 - 06A, and D1790, which shall be not less than four hundredths (0.040) inches thick; or
 4. Other approved material as established in 815 KAR 20:020, Section 4.
- (3) Fiberglass bathtubs, showers, tub enclosures, and shower stalls.
 - (a) Fiberglass bathtubs and tub enclosures shall be produced and labeled as ANSI Z124.1.
 - (b) Acrylic-faced bathtubs shall be produced and labeled as ASTM E84 - 08A or E162.
 - (c) Fiberglass shower stalls and shower receptors shall be produced and labeled as ANSI Z124.2.
 - (4) Metamorphosed carbonate aggregate polyester resinous maratrix-marbleoid bathtubs, lavatories, and shower stalls.
 - (a) Metamorphosed carbonate aggregate polyester resinous maratrix-marbleoid bathtubs shall be produced and labeled as ANSI Z124.1.
 - (b) Lavatories shall be produced and labeled as ANSI Z124.3.
 - (c) Shower stalls shall be produced and labeled as ANSI Z124.2.

Section 7. Fixture Strainers. (1) A fixture, other than a water closet or a pedestal urinal, shall be provided with a strainer.

(2) The outlet area of the strainer shall not be less than the interior area of the trap.

Section 8. Fixture Overflow. The overflow from a fixture shall be optional, but if used, the overflow shall be connected to the inlet side of a trap and accessible for cleaning.

Section 9. Fixture Additions. A fixture added to a plumbing system shall be installed to comply with all applicable sections of the code.

Section 10. Defective Fixtures. If a newly installed fixture is found to be defective by the department or if an old fixture is found to be in an unusable condition, it shall be repaired, replaced, or removed within thirty (30) days upon written notice from the department.

Section 11. Conservation of Water. (1) Showers. A shower used for other than safety reasons shall be equipped with an approved flow control device, which shall limit the total flow to a maximum of two and one-half (2.5) gallons per minute per shower head.

(2) Lavatories.

(a) Public facilities (domestic hot water only). Lavatories in restrooms of public facilities shall be equipped with an outlet device, which shall limit the flow of domestic hot water to a maximum of seventy five hundredths (0.75) gallons per minute.

(b) Non-public facilities (domestic hot and cold water). Lavatory faucets other than those in restrooms of public facilities shall be equipped with a flow control device, which shall limit the flow of domestic water to a maximum of two (2.0) gallons per minute.

(c) Sink faucets (domestic hot and cold water). Sink faucets shall be equipped with a flow control device, which shall limit the flow of domestic water to a maximum of two and one-half (2.5) gallons per minute.

(3) Water closets.

(a) Residential (private use) installations. A water closet for private use in a single family dwelling, duplex, or townhouse, condominium or apartment unit shall not exceed one and six-tenths (1.6) gallons per flush.

- (b) Commercial (public use) installations. A water closet for public use, including a commercial building, shall not exceed three and one-half (3.5) gallons per flush.
- (4) Urinals. A urinal shall not exceed one (1.0) gallon per flush.
- (5) (a) The provisions of this section shall apply to new construction, renovation, or replacement in an existing structure.
- (b) Upon compliance with the requirements of this section, the department shall permit the installation of a tank type water closet equipped with devices found by the inspector to meet applicable specifications in water closets having a tank capacity in excess of three and one-half (3 1/2) gallons (thirteen and three-tenths (13.3) liters).
- (c) The department shall allow the use of a standard flush water closet and a urinal that does not meet the specific specifications if the configuration of the building drainage system requires a greater quantity of water to adequately flush the system, or if the owner requests the use of antique fixtures that would not be equipped for reduced flow.

Section 12. Specifications. (1) Copies of ANSI specifications identified in this administrative regulation may be obtained, subject to applicable copyright law, by writing the American National Standards Institute, 1430 Broadway, New York, New York 10018.

(2) Copies of ASTM specifications identified in this administrative regulation may be obtained, subject to applicable copyright law, by writing the American Society for Testing Materials, 1916 Race Street, Philadelphia, Pennsylvania 19103. (PC-7-9; 1 Ky.R. 483; eff. 3-12-1975; 2 Ky.R. 455; eff. 4-14-1976; 3 Ky.R. 448; eff. 1-5-1977; Recodified from 401 KAR 1:040, 7-5-1978; 8 Ky.R. 361; 769; eff. 1-6-1982; 9 Ky.R. 46; eff. 8-11-1982; 833; eff. 2-2-1983; 1237; eff. 6-1-1983; 10 Ky.R. 453; eff. 11-2-83; 11 Ky.R. 73; eff. 8-7-1984; 13 Ky.R. 785; eff. 11-11-1986; 1940; eff. 6-9-1987; 16 Ky.R. 1270; eff. 1-25-1990; 19 Ky.R. 1002; 1387; eff. 12-8-1992; 20 Ky.R. 3117; eff. 7-7-1994; 21 Ky.R. 1391; eff. 1-9-1995; 2533; eff. 6-1-1995; 23 Ky.R. 3975; eff. 6-25-1997; 32 Ky.R. 2365; 33 Ky.R. 406; eff. 9-1-2006; 35 Ky.R. 2588; 36 Ky.R. 85; eff. 7-29-2009; 37 Ky.R. 2759; eff. 8-5-2011; 41 Ky.R. 169; eff. 9-24-2014; 46 Ky.R. 1664, 2429; eff. 6-2-2020.)

815 KAR 20:080. Waste pipe size.

RELATES TO: KRS Chapter 318

STATUTORY AUTHORITY: KRS 198B.040(10), 318.130

NECESSITY, FUNCTION, AND CONFORMITY: KRS 318.130 requires the department to promulgate administrative regulations establishing the Kentucky State Plumbing Code to regulate plumbing, including the sizes of waste piping. This administrative regulation establishes the minimum size of waste piping required for certain fixtures.

Section 1. The minimum size (nominal inside diameter) of traps, soil, or waste branches for a given fixture shall not be less than that established in the following table:

	Minimum Size (in inches)		
	Trap	Branch	Fixture Unit
Automatic clothes washer	2	2	2
Basement floor drain	3	3	3
Bath: sitz	1 1/2	1 1/2	2
Bathtub	1 1/2	1 1/2	1 1/2
Combination fixture	2	2	2
Dental cuspidor	2	2	2
Dishwasher	1 1/2	1 1/2	1 1/2
Disposal unit	1 1/2	1 1/2	1 1/2
Drinking fountain	1 1/4	1 1/4	1
Floor drain in residential laundry room	2	2	2
Floor drain in toilet room	3	3	3
Floor drain in utility room	3	3	3
Industrial floor drain	4	4	4
Kitchen sink unit	1 1/2	1 1/2	1 1/2
Laundry tray	1 1/2	1 1/2	1 1/2
Lavatories	1 1/4	1 1/4	1
Santistand	3	4	6
Shower stall	1 1/2	1 1/2	1 1/2
Sink: bar or soda fountain	1 1/2	1 1/2	1 1/2
Sink: barium	2	2	2
Sink: chemical	1 1/2	1 1/2	1 1/2
Sink: clinic	3	4	6
Sink: kitchen, residence	1 1/2	1 1/2	1 1/2
Sink: plaster	2	2	2
Sink: service	3	3	3
Sink: service wall type	2	2	2
Sink: three compartment	2	2	2
Urinal: lip	1 1/2	1 1/2	1 1/2
Urinal: pedestal	3	3	3
Urinal: stall	2	2	2
Urinal: trough	1 1/2	1 1/2	1 1/2
Water closet: Greater than 1.6 gallons per flush	3	3 or 4	6
Water closet: 1.6 gallons per flush or less	3	3 or 4	4

(Recodified from 401 KAR 1:050, 7-5-78; Am. 9 Ky.R. 47; eff. 8-11-1982; TAm eff. 8-9-2007; 43 Ky.R. 460; eff. 11-16-2016; 46 Ky.R. 1667; eff. 6-2-2020.

815 KAR 20:090. Soil, waste, vent systems, traps, and clean-outs.

RELATES TO: 318.015, 318.130, 318.150,

STATUTORY AUTHORITY: KRS 198B.040(10), 318.130

NECESSITY, FUNCTION, AND CONFORMITY: KRS 318.130 requires the department to promulgate administrative regulations establishing the Kentucky State Plumbing Code regulating plumbing, including the methods and materials that may be used in Kentucky for soil, waste, and vent systems. This administrative regulation establishes the minimum requirements for and manufacturer's specification number of the material accepted in the installation and design of soil, waste, vent systems, traps, and clean-outs in each type of plumbing system.

Section 1. Materials. (1) Main or branch soil, waste, and vent pipes and fittings within or underneath a building shall be:

- (a) Hub and spigot extra heavy or service weight cast iron;
 - (b) No-hub service weight cast iron;
 - (c) Galvanized steel;
 - (d) Galvanized wrought iron;
 - (e) Lead;
 - (f) Brass;
 - (g) Types K, L, M, and DWV copper;
 - (h) Standard high-frequency welded tubing produced and labeled with the latest ASTM specifications;
 - (i) Types R-K, R-L, R-DWV brass tubing;
 - (j) DWV brass tubing produced and labeled as ASTM B587;
 - (k) Seamless stainless steel tubing;
 - (l) Grade G or H produced and labeled as ASTM A312;
 - (m) PVC schedule 40 or 80 produced and labeled as ASTM D2665, D1784, and F891;
 - (n) Coextruded composite PVC pipe produced and labeled ASTM F1488;
 - (o) ABS schedule 40 or 80 produced and labeled as ASTM D2661, F1488, or F628;
 - (p) CPVC schedule 40 or 80; or
 - (q) Silicon iron or borosilicate.
- (2) A main or branch soil waste and vent pipe and fittings underground shall either be:
- (a) Hub and spigot extra heavy or service weight cast iron;
 - (b) No-hub service weight cast iron;
 - (c) Type K or L copper pipe;
 - (d) Type R-K, R-L brass tubing;
 - (e) Lead; or
 - (f) Silicon iron or borosilicate pipe and fittings or plastics DWV established in this section.
- (3) Underground waste pipe installed beneath a concrete slab shall:
- (a) Not be less than two (2) inches in diameter; and
 - (b) Extend no less than twelve (12) inches above the concrete slab.
- (4) A trap for a bathtub, lavatory, sink, or other similar fixture shall be made of:
- (a) Tubular brass;
 - (b) Tubular ABS or PVC produced and labeled as ASTM F409;
 - (c) Cast brass;
 - (d) Cast iron;
 - (e) Lead;
 - (f) Schedule 40 PVC;
 - (g) Schedule 40 ABS;
 - (h) Grade G or H produced and labeled as ASTM A312; or
 - (i) CPVC schedule 40 or 80.
- (5) A tubular or schedule 40 PVC, or a tubular or schedule 40 ABS p-trap shall be either the union-joint or solvent welded type.

- (6) A tubular brass trap shall be seventeen (17) gauge.
- (7) A tubular brass trap, tubular PVC trap, or tubular ABS trap shall not be installed below the finished floor serving a fixture.
- (8) The threads in a cast brass or cast iron trap shall be tapped out of solid metal.
- (9) A lead trap shall be extra heavy.

Section 2. Trap Requirements. (1) Trap placement. A fixture shall be separately trapped by a water-seal trap placed as near as possible to the fixture, but not to exceed ten (10) inches from the bottom of the fixture to the dip of the seal.

(2) Water seal. A fixture trap shall have a water seal not less than two (2) inches nor more than four (4) inches.

(3) Waste discharge. Waste from a bathtub or other fixture shall not discharge into a water closet bend.

(4) Double trap prohibition. A fixture shall not be double trapped.

(5) A trap shall have a full-bore, smooth interior waterway.

(6) Self-cleaning. A trap shall be self-cleaning.

(7) Trap clean-outs. A trap clean-out shall be optional.

(8) Trap levels and protection. A trap shall be:

(a) Set true with respect to its water seal; and

(b) Protected from frost and evaporation

(9) Trap primers. Trap primers shall be required on:

(a) Floor drains only in mechanical rooms or boiler rooms; and

(b) All open receptacles that receive the discharge from a temperature and pressure relief device discharge only.

(10) Protected Traps and Vents.

(a) A fixture trap shall be protected against siphonage and backpressure.

(b) Air circulation shall be assured by means of an individual vent.

(c) A crown vent shall not be permitted.

(d) An open drain, such as a hub drain or open receptacle, shall not be installed within a plenum space.

(11) Distance of Trap from Vent.

(a) 1. The distance between the vent and the fixture trap shall be measured along the center line of the waste or soil pipe from the vertical inlet of the trap to the vent opening.

2. The fixture trap vent, except for a water closet or a similar fixture, shall not be below the dip of the trap, and each ninety (90) degree turn in the waste line of the main waste, soil, or vent pipe shall be washed.

3. A fixture trap shall have a vent located with a developed length not greater than that in the following table:

Size of Fixture Drain (In Inches)	Distance Trap to Vent
1 1/4	2 ft. 6 in.
1 1/2	3 ft. 6 in.
2	5 ft.
3	6 ft.
4	10 ft.

- (b) A fixture branch on a water closet shall not be more than four (4) feet six (6) inches.
- (12) Grease traps.
 - (a) If a grease trap is installed, it shall be:
 - 1. Placed as near to the fixture it serves as practical; and
 - 2. Approved by the department.
 - (b) A grease trap used inside a building shall:
 - 1. Have a sealed cover; and
 - 2. Be properly vented.
 - (c) A grease trap for a restaurant, food service establishment, or other business establishment shall be installed:
 - 1. As required by municipal ordinance; or
 - 2. As required by 902 KAR 10:085, if a food establishment uses a private sewage system.
- (13) Sand Traps. A sand trap shall be:
 - (a) Readily accessible; and
 - (b) Serve the purpose intended.
- (14) Slip joints.
 - (a) Slip joints shall be permitted on the inlet side of the trap.
 - (b) A single one and one-half (1 1/2) inch slip joint connection with an elastomeric gasket shall be permitted on the outlet side of a one and one-half (1 1/2) inch trap.

- Section 3. Pipe Clean-out Requirements.** (1) The bodies of clean-out ferrules shall be made in a standard pipe size, conforming in thickness to that of the pipe and fittings and shall not extend less than one-quarter (1/4) inch above the hubs in which they are placed.
- (2) The cleanout cap or plug shall be yellow-brass, PVC, or ABS no less than one-eighth (1/8) inch thick and shall have a raised nut or recessed pocket for removal.
- (3) In a building served by a stack over forty-five (45) feet in height, a clean-out shall be provided at the base of each vertical waste or soil stack.
- (4) There shall be at least one (1) clean-out in the building drain with a full-size branch inside the wall or outside the building at a point not to exceed two (2) feet from the foundation wall. This cleanout shall be a two (2) directional fitting or a combination of sanitary tees or tee wyes to allow cleaning in both directions.
- (5) If located outside the building, the cleanout shall be extended to the finished grade for accessibility.
- (6) A cleanout shall be of the same nominal size as the pipe it serves up to four (4) inches and shall not be less than four (4) inches for larger pipe.
- (7) A cleanout installed on a four (4) inch sewer shall be a two (2) directional fitting or a combination of sanitary tees or tee wyes to allow cleaning in both directions.
- (8) The distance between clean-outs in all sewers shall not exceed 150 feet.
- (9) An underground cleanout in a building shall be:
 - (a) Flush with the floor or wall; or
 - (b) Accessible by a manhole.
- (10) A floor or wall connection of a fixture shall be regarded as a cleanout, except where the house drain enters a building.

Section 4. Grades and Supports of Horizontal Piping.

- (1) (a) Horizontal piping shall run in practical alignment and at a uniform grade of not less than one-eighth (1/8) inch per foot and shall be supported or anchored in accordance with the manufacturer's recommendations.
 - (b) The supports or anchors shall not be placed at intervals that exceed ten (10) feet in length.
- (2) A stack shall be supported at its base, and each pipe shall be rigidly secured.
- (3) No-hub pipe and fittings shall be supported at each joint of pipe and fittings.
- (4) PVC and ABS schedule forty (40) horizontal piping shall be supported at:
 - (a) Intervals not to exceed four (4) feet;

- (b) The base of each vertical stack; and
- (c) Each trap branch as close to the trap as possible.
- (5) PE pipe and fittings shall be continuously supported with a V channel.
- (6) A stack shall be rigidly supported at its base and at the floor level.

Section 5. Change in Direction. (1) Except as provided in subsections (2), (3), or (4) of this section, a change in direction shall be made by the appropriate use of a forty-five (45) degree wye, half-wye, quarter (1/4), sixth (1/6), eighth (1/8) or sixteenth (1/16) bend.

(2) A single sanitary tee may be used in a vertical stack.

(3) A sanitary tee may be turned on its back or side. If turned on its back or side, a sanitary tee shall not be placed at an angle of more than forty-five (45) degrees.

(4) A double sanitary tee may be used on a vertical soil, waste, and vent line.

Section 6. Direct Flow Fittings and Continuous waste. A kitchen sink unit or a fixture with more than one (1) unit may be connected with a continuous waste, if a directional flow fitting is used. Continuous waste shall be either seventeen (17) gauge tubular brass, schedule 40 ABS, schedule 40 PVC, tubular ABS, or tubular PVC.

Section 7. Prohibited Fittings.

- (1) The following shall be prohibited:
- (a) A double hub bend and double hub tee or inverted hub on a sewer, soil, or waste line;
 - (b) The drilling and tapping of a house sewer or house drain, soil, waste, or vent pipe;
 - (c) The use of a saddle hub; and
 - (d) Pipe installed with a hub or restriction that reduces the area or capacity of the pipe.
- (2) Prohibited traps. A trap shall not be used if the trap depends upon:
- (a) The action of a movable part; or
 - (b) Concealed interior partition for its seal.

Section 8. Dead Ends. A dead end shall not be used in the installation of a drainage system.

Section 9. Protection of Material. (1) A pipe passing under or through a wall shall be protected from breakage.

(2) A pipe passing through or under cinder, concrete, or other corrosive material shall be protected against external corrosion.

(3) (a) Soil, waste, or vent pipe shall not be installed or permitted outside a building unless adequate provision shall be made to protect it from frost.

(b) The vent shall be increased to full size, the size of the increaser required as if it were passing through the roof.

Section 10. Size of Soil and Waste Pipe per Fixture Unit on One (1) Stack. (1) The following table, based on the rate of discharge from a lavatory as a unit, shall be employed to determine fixture equivalents:

Pipe Size (In Inches)	Maximum Developed Length	Fixture Units
1 1/4	25 ft.	1
1 1/2	60 ft.	2
2	80 ft	6
2 1/2	100 ft	12
3	225 ft	36
4	unlimited	172
5	unlimited	342
6	unlimited	576
8	unlimited	1600
10	unlimited	2900
12	unlimited	4600

(2) A water closet shall be on a minimum of a three (3) inch soil and waste pipe with a maximum of three (3) water closets or soil discharging fixtures per three (3) inch soil and waste pipe. Four (4) water closets with a maximum flushing rate of one and six-tenths (1.6) gallons per flush per water closet shall be allowed to discharge into a three (3) inch soil and waste pipe.

Section 11. Soil and Vent Stacks. (1) A building in which a plumbing fixture is installed shall have a soil or waste and vent stack, or stacks, extending full size through the roof.

(2) A soil or waste and vent stack shall be as direct as possible and free from sharp bends or turns.

(3) The required size of the soil or waste and vent stack shall be determined from the total fixture units connected to the stack in accordance with Section 10 of this administrative regulation except that more than:

(a) Three (3) water closets with a flush rate of three and five-tenths (3.5) gallons per flush shall not discharge into a three (3) inch stack; and

(b) Four (4) water closets with a flush rate of one and six-tenths (1.6) gallons per flush or less shall not discharge into a three (3) inch stack.

Section 12. Future Openings. An existing opening or an opening installed in a plumbing system for future use shall be complete with its soil, waste, and vent piping and shall comply with this administrative regulation.

Section 13. House Drain. (1) The size of the house drain shall be determined by the total number of fixture units connecting to the house drain. The total area of vents through the roof shall be equal to that of the house drain with a minimum of one (1) three (3) inch stack.

(2) If a three (3) inch house drain enters a building, it shall be attached to a three (3) inch stack. One (1) floor drain may be added to the house drain if it conforms with the requirements of Section 23 of this administrative regulation, without counting toward the fixture units of the system.

Section 14. Soil and Waste Stacks, Fixture Connections. (1) A soil and waste stack or branch shall have correctly faced inlets for fixture connections.

(2) Each fixture shall be independently connected to the soil or waste system.

(3) A fixture connection to a water closet, floor-outlet pedestal sink, pedestal urinal, or other similar plumbing fixture shall be:

- (a) Cast iron;
- (b) Lead;
- (c) Brass;
- (d) Copper; or
- (e) Plastic closet bend.

(4) A three (3) inch closet bend shall have a four (4) inch by three (3) inch flange.

Section 15. Changing Soil and Vent Pipes in an Existing Building. Soil, waste, and vent piping shall be replaced with appropriate size and materials for new work as prescribed by this administrative regulation, if:

(1) The fixtures are to be changed or replaced; and

- (2) (a) The soil, waste, and vent piping in an existing building is not extended undiminished through the roof; or
- (b) There is sheet metal soil or waste piping.

Section 16. Prohibited Connections. (1) A fixture connection shall not be made to a lead bend or a branch of a water closet or a similar fixture.

(2) A vent pipe above the highest installed fixture on a branch or main shall not be used as a soil or waste pipe.

Section 17. Roof Extensions. (1) A roof extension of soil and waste stacks shall run full size at least one (1) foot above the roof.

(2) If the roof is used for purposes other than weather protection, the extension shall not be less than five (5) feet above the roof.

- (3) (a) A stack of less than three (3) inches in diameter shall be increased to a minimum of three (3) inches in diameter before passing through a roof.
- (b) If a change in diameter is made, the fitting shall be placed at least one (1) foot below the roof.

Section 18. Terminals. (1) Terminals on buildings. The terminus of a stack or vent shall extend at least two (2) feet above the top edge of a door, window, scuttle, or air shaft, if the roof terminus is:

- (a) Within ten (10) feet of the top, bottom, face, or side edge of a door, window, scuttle, or air shaft; and
- (b) Not screened from the opening by a projecting roof or building wall.

(2) Terminals Adjoining High Buildings.

(a) Except when soil, waste, or vent piping is protected from freezing, a pipe extension of a new or existing building shall be installed inside the building and shall not run or be placed on an outside wall.

(b) If the new building is built higher than the existing building, the owner of the new building shall not locate a window within ten (10) feet of an existing vent stack on the lower building.

Section 19. Main Vents to Connect at Base. (1) All main vents or vent stacks shall:

- (a) Connect full size at the base of the main soil or waste pipe at or below the lowest fixture branch; and
 - (b) Extend undiminished in size through the roof or be reconnected with the main soil or vent stack at least six (6) inches above the rim of the highest fixture.
- (2)
- (a) Except as established in paragraph (b) of this subsection, if it becomes necessary to increase the size of a vertical vent stack, the entire stack shall be increased from its base.
 - (b) If the height of a stack which does not serve as the main vent is less than forty-five (45) feet, it shall not be required to be increased from its base.

Section 20. Vents; Required Sizes. (1) The required size of a vent or vent stack shall be determined by the total number of fixture units it serves and the developed length of the vent, interpolating, if necessary, between permissible length of vent given in the following table:

MAXIMUM PERMISSIBLE LENGTHS OF VENTS		
Pipe Size (In Inches)	Maximum Length (In Feet)	Fixture Units
1 1/4	30	2
1 1/2	150	10
2	200	24
2 1/2	250	36
3	300	72
4	400	240
5	600	420
6	800	720

(2) Except for a residential installation, if a fixture opening is installed more than twenty-five (25) feet of developed length from the point where it is connected to the main soil or waste system, or, if more than ten (10) feet of vertical piping is used, the vent shall be continued full size through the roof or returned full size to the main vent.

Section 21. Branch and Individual Vents. A branch or individual vent shall not be less than one and one-fourth (1 1/4) inches in diameter and shall not exceed the maximum length permitted for a main vent.

Section 22. Vent Pipes Grades and Connections. (1) A vent or branch vent pipe shall be free from drops or sags and be so graded and connected as to drip back to the soil or waste pipe by gravity.

(2) If a vent pipe connects to a horizontal soil or waste pipe, the vent branch shall be taken off above the center line of the pipe, and the vent pipe shall rise vertically at an angle of forty-five (45) degrees to the vertical, to a point six (6) inches above the fixture it is venting before offsetting horizontally or connecting to the branch, main, waste, soil or vent.

Section 23. Vents Not Required; Backwater Traps, Subsoil Catch Basin, and Basement Floor Drains.

(1) A vent shall not be required on a backwater trap, subsoil catch basin trap, or a basement floor drain if the basement floor drain branches into the house drain so that measuring along the flow line from the center of the stack, the floor drain shall not be closer than five (5) feet of the stack, nor farther than twenty (20) feet.

(2) A basement floor drain shall not require an individual vent if it branches into the house drain so that measuring along the flow line from the center of the house drain the basement floor drain shall not be farther than ten (10) feet from the house drain.

Section 24. Permissible Common Vent Conditions. (1) A common vent or a common soil and waste pipe may be used if:

(a) Two (2) water closets, two (2) lavatories, or two (2) fixtures of identical purpose are located on opposite sides of a wall or partition; or

(b) Directly adjacent to each other within the distance established in Section 2(11) of this administrative regulation measured along the center line of the flow of water.

(2) Double sanitary tee or sanitary cross shall not be used if a common vent or a common soil and waste pipe are connected through a double fixture fitting for a water closet of less than 1.6 gallons per flush.

(3) A common vent or common soil and waste pipe shall be vented in accordance with this administrative regulation.

Section 25. Floor Drain Individual Vent Not Required. (1) A manufacturer's floor drain shall not require an individual vent if placed on a waste line for a floor drain within the distance of ten (10) feet from the main waste line, or stack, if the base of the stack is washed and the stack or stacks are undiminished through the roof, or connected to a main vent stack.

(2) An open receptacle may be connected to a floor drain line without being vented if the waste line discharges into a four (4) inch master trap before entering the sanitary sewer system.

Section 26. Floor Drain at a sewage and water treatment plant. A floor drain or service sink installed on the operational floor level of a sewage and water treatment plant facility that discharges into an open sump and is not connected directly to the sanitary sewage system shall not be required to be trapped or vented.

Section 27. House Drain Material. A house drain shall be:

- (1) Extra heavy cast iron;
- (2) Service weight cast iron;
- (3) Brass;
- (4) Type (K) or (L) copper;
- (5) Lead;
- (6) ABS or PVC plastic; or
- (7) Duriron.

Section 28. Indirect Waste Connections.

(1) Waste pipe from a refrigerator drain or other receptacle where food is stored or waste water from a water cooled compressor shall connect indirectly with the house drain, soil, or waste pipe.

(2) The drain shall be vented to the outside air.

(3) The waste pipe shall discharge into an open sink or another approved open receptacle that is properly supplied with water in accordance with this administrative regulation.

(4) The connection shall not be located in an inaccessible or unventilated area.

Section 29. Bar and Soda Fountain Wastes.

- (1)
 - (a) A bar and soda fountain waste, sink, or receptacle shall have a one and one-half (1 1/2) inch P trap and branches.
 - (b) The main shall not be less than two (2) inches.
 - (c) The fresh air pipe shall not be less than one and one-half (1 1/2) inches.
 - (d) The main waste line shall discharge into a properly vented and trapped open receptacle inside or outside a building.
- (2) A floor receptor or floor sink may be installed flush with the finished floor if it has a full grate with an attached funnel to receive indirect waste.
- (3) A floor receptor or floor sink installed specifically for the indirect wastes from a tilting braising pan, tilting kettle, or other similar equipment may be installed level with or slightly recessed in the floor if the receptor is equipped with a proper strainer and receives no other indirect waste.

Section 30. Open Receptacles. Soil or waste piping receiving the discharge from an open receptacle shall be at least six (6) inches above the surface of the ground if it discharges into a septic system.

Section 31. Refrigerator and Condensate Wastes. (1) A refrigerator or condensate discharge waste pipe shall not be less than:

- (a) One and one-half (1 1/2) inches for one (1) to three (3) openings; and
 - (b) Two (2) inches for four (4) to eight (8) openings.
- (2) Each opening shall be trapped.
- (3) The waste piping shall be equipped with sufficient cleanouts to allow for thorough cleaning.

Section 32. Overflow Pipes. (1) Waste from a water supply tank or exhaust from a water lift shall not be directly connected to a house drain, soil, or waste pipe.

- (2) The waste pipe shall discharge upon a roof or into a trapped open receptacle.

Section 33. Acid and Chemical Wastes. (1) A corrosive liquid shall not be permitted to discharge into the soil, waste, or sewer system unless otherwise permitted by this administrative regulation.

- (2) The waste shall be thoroughly diluted or neutralized by passing through a properly constructed and acceptable dilution or neutralizing pit before entering the house sewer.

Section 34. Laboratory Waste Piping. (1) Laboratory waste piping shall be sized in accordance with this administrative regulation and each fixture shall be individually trapped.

- (2) A continuous waste and vent pipe system may be used if the waste discharges into a vented dilution pit outside the building with a vent equal to the size of the drain. The vent may be eliminated if the pit has a ventilated cover.
- (3) If a dilution pit is not required and is not used, the fixtures shall be individually vented.
- (4) If construction conditions permit, the base of the stack of the continuous waste and vent system shall be washed by the last fixture opening, and continue full size independently through the roof.
- (5) A fixture branch exceeding more than the distance established in the table in Section 2(11) of this administrative regulation from the main shall be revented, and the distance shall be measured from the center of the main to the center of the vertical riser.
- (6)
 - (a) A fixture connection shall rise vertically to a height so that the trap shall not be lower than twelve (12) inches from the bottom of the sink.
 - (b) Two (2) or more sinks may be connected into a common waste before entering the riser of the continuous waste and vent system, if the fixtures are not more than five (5) feet from the center of one (1) fixture to the center of the other.

Section 35. Acid Waste Piping.

- (1) Underground piping for acid wastes shall be:
 - (a) Extra heavy salt glazed vitrified pipe;
 - (b) Silicon iron;
 - (c) Lead;
 - (d) PE pipe and fittings produced and labeled as ASTM D204;
 - (e) PP pipe produced and labeled as ASTM D4101;
 - (f) PP pipe and fittings produced and labeled as ASTM F1412;
 - (g) CPVC Chemical Waste Drainage Systems meeting ASTM F2618; or
 - (h) Other materials approved in 815 KAR 20:020, Section 4.
- (2) Piping for acid wastes and vents above ground shall be:
 - (a) Silicon iron;
 - (b) Lead;
 - (c) Borosilicate;
 - (d) PE pipe produced and labeled as ASTM D120462T;
 - (e) PP pipe produced and labeled as ASTM D410185;
 - (f) Filament-wound reinforced thermosetting resin pipe produced and labeled as ASTM D2996 (green or poly thread); or
 - (g) CPVC Chemical Waste Drainage Systems meeting ASTM F2618.

Section 36. Special Vents. A flat vent may be allowed if the design of the building prohibits the type of venting required by this administrative regulation.

Section 37. Basement Floor Drains. (1) A basement floor drain shall be:

- (a) Connected to the house sewer;
 - (b) Properly trapped and vented;
 - (c) Readily accessible for cleaning; and
 - (d) Of sufficient size to serve the purpose intended.
- (2) If a drain is subject to back flow or back pressure, the drain shall be equipped with a back water valve that complies with Section 38 of this administrative regulation.
- (3) (a) A basement floor drain shall not be connected to the house sewer and shall be exempt from this section if, prior to the installation, the local health department or sanitary sewage system board, plant, district, or treatment plant owner notifies the division, in writing, that connection is detrimental to the functioning of the sanitary sewer system or subsurface system.
- (b) If the drain is not to be connected to the house sewer, the installation shall also be exempt from the waste, trap, and venting provisions of this code.

Section 38. Back Water Valves. A backwater valve shall be:

- (1) Made of noncorrosive material; and
- (2) Constructed to ensure a positive mechanical seal, except if discharging waste.

Section 39. Residential Laundry Room Floor Drains. A two (2) inch floor drain with an individual waste and vent may be installed in a residential laundry room.

(Recodified from 401 KAR 1:060, 7-5-1978; Am. 6 Ky.R. 134; eff. 1-2-1980; 7 Ky.R. 509; eff. 1-7-1981; 846; eff. 6-3-1981; 9 Ky.R. 834; eff. 2-2-1983; 1238; eff. 6-1-1983; 14 Ky.R. 1129; eff. 1-4-1988; 16 Ky.R. 72; eff. 8-22-1989; 1272; 1590; eff. 8-22-1989; 18 Ky.R. 2722; eff. 4-3-1992; 3537; 19 Ky.R. 411; eff. 8-1-1992; 1192; 1556; eff. 1-4-1993; 22 Ky.R. 1386; eff. 3-7-1996; 23 Ky.R. 2691; 2990; eff. 2-10-1997; 3978; eff. 6-25-1997; 27 Ky.R. 1905; 2796; eff. 3-22-2001; 30 Ky.R. 2393; 31 Ky.R. 88, eff. 8-6-2004; 32 Ky.R. 2367; 33 Ky.R. 408; eff. 9-120-2006; 34 Ky.R. 1239; 1750; eff. 2-1-2008; 35 Ky.R. 2594; 36 Ky.R. 88; eff. 7-29-2009; 35 Ky.R. 2594; 36 Ky.R. 88; 1352; eff. 3-5-2010; 41 Ky.R. 175; eff. 9-24-2014; 43 Ky.R. 461; eff. 11-16-2016; 46 Ky.R. 1668, 2431; eff. 6-2-2020.

815 KAR 20:120. Water supply and distribution.

RELATES TO: KRS 318.130, 318.150, 318.165,

STATUTORY AUTHORITY: KRS 198B.040(10), 318.130

NECESSITY, FUNCTION, AND CONFORMITY: KRS 318.130 requires the department to promulgate administrative regulations establishing the Kentucky State Plumbing Code regulating plumbing, including the methods and materials that may be used in Kentucky. This administrative regulation establishes the types of piping and pipe sizes required for a potable water supply system and the methods to be used to protect and control the water supply system and requires the manufacturer's specification number of the material accepted in those installations to be identified and published.

Section 1. Quality. (1) The bacteriological and chemical quality of the water supply shall comply with the administrative regulations of the department and the Energy and Environment Cabinet, Department for Environmental Protection, Division of Water KAR Title 401. Toxic material shall be kept out of a potable water system.

- (a) The pipe conveying, and each surface in contact with, potable water shall be constructed of nontoxic material.
 - (b) A chemical or other substance that may produce either a toxic condition, taste, odor, or discoloration in a potable water system shall not be introduced into, or used in, the system.
 - (c) The interior surface of a potable water tank shall not be lined, painted, or repaired with a material that will affect the taste, odor, color, or portability of the water supply if the tank is placed in, or returned to, service.
- (2) Potable water shall be accessible to a plumbing fixture that supplies water for drinking, bathing, culinary use or the processing of a medicinal, pharmaceutical, or food product.
 - (3) The potable water supply system shall be designed, installed, and maintained to prevent contamination from a nonpotable liquid, solid, or gas being introduced into the potable water supply through a cross connection or other piping connection to the system.
 - (4) A cross connection shall meet the requirements of this administrative regulation.
 - (5) A cross connection between a private water supply and a public water supply shall not be made.
 - (6) Closed water systems, protection from excess pressure.
 - (a) If a single check valve is installed in a water system, a thermal expansion tank sized in accordance with manufacturer's instructions or other pressure relief device listed in 815 KAR 20:020 shall be installed in the cold water supply located near the water heater.
 - (b) If a backflow preventer is installed in a water system, a properly sized thermal expansion tank or other pressure relief device listed in 815 KAR 20:020 shall be installed in the water distribution system.
 - (c) If a pressure reducing valve not equipped with a bypass is installed in the cold water supply line to a water heater, a thermal expansion tank or other pressure relief device listed in 815 KAR 20:020 shall be installed in the cold water line near the water heater.
 - (7) Backflow and back siphonage protection. Protection against backflow shall be provided as required in paragraphs (a) through (l) of this subsection in order of degree of protection provided. Backflow shall include both back pressure and back siphonage.
 - (a) An air gap shall provide the best level of protection in all backflow situations. The minimum required air gap shall be determined as follows:
 1. Measurement. The minimum required air gap shall be measured vertically from the lowest end of a potable water outlet to the flood rim or line of the fixture or receptacle into which it discharges.
 2. Size. The minimum required air gap shall be:
 - a. Twice the effective opening of a potable water outlet; or
 - b. If the outlet is a distance less than three (3) times the effective opening away from a wall or similar vertical surface, three (3) times the effective opening of the outlet.

3. The minimum required air gap shall not be less than shown in the following table - Minimum Air Gaps for Plumbing Fixtures.

MINIMUM AIR GAPS FOR PLUMBING FIXTURES		
Fixture	Minimum Air Gap	
	When not affected by near wall (inches)	When affected by near wall (inches)
Lavatories and other fixtures with effective opening not greater than 1/2 inch diameter	1	1 1/2
Sink, laundry trays, gooseneck bath faucets and other fixtures with effective openings not greater than 3/4 inch diameter	1 1/2	2 1/4
Over rim bath fillers and other fixtures with effective openings not greater than 1 inch diameter	2	3
Drinking water fountains – single office not greater than 7/16 (0.437) inch diameter or multiple orifices having total area of 0.150 square inches (area of circle 7/16 inch diameter)	1	1 1/2
Effective openings greater than 1 inch	2 x diameter of effective opening	3 x diameter of effective opening

NOTE 1. Side walls, ribs, or similar obstructions do not affect air gaps if spaced from the inside edge of the spout opening a distance greater than three (3) times the diameter of the effective opening for a single wall, or a distance greater than four (4) times the diameter of the effective opening for two (2) intersecting walls.

NOTE 2. Vertical walls, ribs, or similar obstructions extending from the water surface to or above the horizontal plane of the spout opening require a greater air gap if spaced closer to the nearest inside edge of spout opening than specified in NOTE 1 above. The effect of three (3) or more vertical walls or ribs has not been determined. In this case, the air gap shall be measured from the top of the wall.

(b) Reduced pressure principle back pressure backflow preventer. A reduced pressure principle back pressure backflow preventer shall provide the best mechanical protection against backflow available and shall be considered equivalent to an air gap.

(c) Double check valve assembly. This device shall be a manufactured assembly consisting of two (2) independently acting check valves and including a shutoff valve at each end, and petcock and test gauge for testing the water tightness of each check valve.

(d) Pressure type vacuum breaker.

(e) Atmospheric type vacuum breaker. If applicable, an atmospheric type vacuum breaker shall be installed after the last cutoff valve on the water line. This device may operate under normal atmospheric pressure if the critical level (CL) is installed at the required height in accordance with the table in this paragraph:

CRITICAL LEVEL (CL) SETTINGS FOR ATMOSPHERIC TYPE VACUUM BREAKERS	
Fixture or Equipment	Method of Installation
Aspirators, ejectors, and showers	CL at least 6 in. above flood level of receptacle
Bidets	CL at least 6 in. above flood level of receptacle
Cup beverage vending machines	CL at least 12 in. above flood level of machine
On models without built-in vacuum breakers:	
Dental units	CL at least 6 in. above flood level rim of bowl
Dishwashing machines	CL at least 6 in. above flood level of machine
Flushometers (closet & urinal)	CL at least 6 in. above top of fixture supplied
Garbage can cleaning machines	CL at least 6 in. above flood level of machine
Hose bibs (sinks or receptacles)	CL at least 6 in. above flood level of receptacle served
Hose outlets	CL at least 6 in. above highest point on hose line
Laundry machines	CL at least 6 in. above flood level of machine
Lawn Sprinklers	CL at least 12 in. above highest sprinkler or discharge outlet
Steam tables	CL at least 12 in. above flood level
Tanks & vats	CL at least 6 in. above flood level rim or line

(f) Barometric loop. The use of a barometric loop shall not be acceptable as the primary back siphonage preventer.

(g) Location of backflow and back siphonage preventers.

1. A backflow and back siphonage preventer shall be in an accessible location, and accessible from within the same room as the fixture or connection it protects.
2. A backflow device may be installed in a utility or service space.
3. A device or air gap shall not be installed in a location subject to flooding or freezing.

(h) Inspection of devices.

1. A periodic inspection shall be made of each backflow and back siphonage preventer to determine if it is in proper working condition.
2. A reduced pressure principle back pressure backflow preventer shall be tested on at least an annual basis.
3. Records shall be kept on each inspection.

(i) Approval of devices.

1. Before a device for the prevention of backflow or back siphonage is installed, it shall be identified as meeting the applicable specifications as listed in the application chart included in paragraph (k) of this subsection.
2. A device installed in a building potable water supply distribution system for protection against backflow shall be maintained in good working condition by the person responsible for the maintenance of the system.

(j) Degree of hazard. The protection required at an outlet or connection shall be determined based on the degree of hazard posed by that outlet or connection as follows:

1. Severe hazard, if there is potential for contamination by a toxic substance or disease causing organism;
2. Moderate hazard, if there is potential for contamination by a nontoxic but objectionable substance; or
3. Minor hazard, if there is potential for contamination by a generally nontoxic, nonobjectionable substance, but which may cause the consumer to question the quality of water.

(k) Minimum acceptable protection. An opening or outlet shall be protected by an air gap between the opening and flood level rim if possible. The acceptable protection for various types of outlets or connections shall be as shown in the tables in this paragraph:

TYPE AND PRESSURE	DESCRIPTION	INSTALLED AT	EXAMPLES OF INSTALLATIONS	APPLICABLE SPECIFICATIONS
Reduced pressure principle backflow preventer for high hazard cross connections	Two independent check valves with intermediate relief valve. Supplied with shutoff valves and ball-type test cocks.	All cross connections subject to backpressure or back siphonage if there is a high potential health hazard from contamination. Continuous pressure.	Main supply lines, commercial boilers, cooling towers, hospital equipment, processing tanks, laboratory equipment, waste digesters, car wash, sewage treatment, lawn sprinklers	ASSE No. 1013 AWWA C506 FCCCHR of U.S.C. CSA B.64.4 Sizes 3/4" - 10"
(A) Double check valve assembly for low hazard cross connections	Two independent check valves. Supplied with shutoff valves and ball type test cocks.	All cross connections subject to backpressure if there is a low potential health hazard or nuisance. Continuous pressure.	Main supply lines, food cookers, tanks and vats, commercial pools	ASSE No. 1015 AWWA C506 FCCCHR of U.S.C. CSA B.64.5 Sizes 3/4" - 10"
(B) Dual check valve backflow preventer for low hazard applications	Two independent check valves. Checks are removable for testing	Cross connections if there is a low potential health hazard and moderate flow requirements.	Post ground hydrants	ASSE No. 1024 Sizes 3/4" & 1"
(A) Backflow preventer with intermediate atmospheric vent for moderate hazard cross connections in small pipe sizes	Two independent check valves with intermediate vacuum breaker and relief valve.	Cross connections subject to backpressure or backsiphonage if there is a moderate health hazard. Continuous pressure.	Boilers (small), cooling towers (small), dairy equipment residential	ASSE No. 1012 CSA B.64.3 Sizes 1/2" & 3/4"
(B) Backflow preventer for carbonated beverage machine	Two independent check valves with a vent to atmosphere	On potable water distribution lines serving beverage dispensing equipment to prevent backflow of carbon dioxide gas and carbonated water into the water supply system.	Postmix carbonated beverage machine	ASSE 1022
(C) Laboratory faucet and double check valve with intermediate vacuum breaker in small pipe sizes for moderate to low hazard	Two independent check valves with intermediate vacuum breaker and relief vent.	Cross connection subject to backpressure or backsiphonage if there is a moderate to low health hazard.	Laboratory faucets and pipe lines, barber shop and beauty parlor sinks	ASSE No. 1035 (N-LF9)
(A) Atmospheric vacuum breakers for moderate to high hazard cross connections	Single float and disc with large atmospheric port.	Cross connections not subject to backpressure or continuous pressure. Install at least 6" above fixture rim. Protection against backsiphonage only.	Process tanks, dishwashers, soap dispensers, washing machines	ASSE No. 1001 AN SI.A112.1.1 CSA B.64.1.1 FCCCHR of U.S.C. Sizes 1/4" - 3"
(B) Antisiphon pressure breakers for moderate to high hazard cross connections	Spring loaded single float and disc with independent 1st check. Supplied with shutoff valves and ball type test cocks.	This valve is designed for installation in a continuous pressure potable water supply system 12" above the overflow level of the system being supplied. Protection against backsiphonage only.	Laboratory equipment, cooling towers, commercial laundry machines, swimming pools, commercial plating tanks, large toilet total & urinal facilities, degreasers, photo tanks, livestock water systems, lawn sprinklers	ASSE No. 1020 CSA B.64.1.2 FCCCHR of U.S.C. Sizes 1/2" - 2"
(C) Hose connection vacuum breakers for residential and industrial hose supply outlets	Single check with atmospheric vacuum breaker vent.	Install directly on hose bibs, service sinks and wall hydrants. Not for continuous pressure.	Hose bibs, service sinks, hydrants	ASSE No. 1011 CSA B.64.2 Size 3/4" Hose

CROSS CONNECTIONS, DEGREE OF HAZARD AND ACCEPTABLE PROTECTION FOR VARIOUS PLUMBING OUTLETS AND CONNECTIONS									
Degree of Hazard				Acceptable Protection					
Type of Connection				Backflow			Backsiphonage		
	Severe	Moderate	Minor	Air Gap	Reduced Pressure Device	Double Check Valve Assembly	Pressure Type Vacuum Breaker	Atmospheric Type Vacuum Breaker	
I. Connections subject to back pressure from:									
A. Pumps, tanks, and lines handling:									
1. Toxic substance	X			X					
2. Nontoxic substance	X	X		X			X		
B. Boilers									
1. With chemical additives			X	X		X			
2. Without chemical additives	X	X			X		X		
C. Gravity due to obvious site conditions subject to:									
1. Contamination by toxic substances			X	X		X			
2. Contamination by nontoxic substances	X	X			X		X		
II. Water outlets and connections not subject to back pressure:									
A. Connection to sewer or sewage pump									
		X				X			
B. Outlet to receptacles containing toxic substances									
	X	X		X		X		X	
C. Outlet to receptacles containing nontoxic substances									
	X	X		X		X		X	X
D. Outlet into domestic water tanks									
		X					EACH CASE TREATED SEPARATELY		
E. Flush valve toilets									
	X	X		X		X		X	
F. Flush valve urinals									
	X	X		X		X		X	
G. Outlets with hose attachments subject to contamination from:									
1. Toxic substance									
	X	X		X		X		X	
2. Nontoxic substance									
	X	X		X		X		X	
H. Outlets to recirculating cooling tower:									
1. With chemical additives									
	X		X		X				
2. Without chemical additives									
	X		X		X		X		

(l) Protection of potable water system. A potable water opening, outlet, or connection, except one (1) that serves a residential unit, shall be protected against backflow in accordance with paragraphs (a) through (k) of this subsection.

Section 2. Water Required. (1) A building equipped with a plumbing fixture and used for habitation or occupancy shall be equipped with a supply of potable water.
(2) In a building used as a residence or a building in which people assemble or are employed, both hot and cold water shall be supplied.

Section 3. Water Service. (1) The water service piping to a building shall:

- (a) Not be less than three-fourths (3/4) inch nominal pipe size; and
 - (b) Be of sufficient size to permit a continuous and ample flow of water to each fixture in the building.
- (2) If the water service piping is made of plastic or other nonconductive piping, the water service piping shall be installed with an insulated copper tracer wire adjacent to the piping.
- (a) Access shall be provided to the tracer wire within the building at the main supply control valve.
 - (b) The tracer wire shall:
 - 1. Not be less than eighteen (18) AWG; and
 - 2. Be suitable for direct burial.

(3) Except as provided in this subsection, the underground water service pipe from the main or water supply system to the water distribution system shall not be less than five (5) feet apart horizontally from the house sewer and shall be separated by undisturbed or compacted earth. The pipe may be placed in the same trench if:

- (a) The bottom of the water service pipe at all points is at least eighteen (18) inches above the top of the sewer at its highest point;
- (b) The water service pipe is placed on a solid shelf excavated at one (1) side of the common trench; and
- (c) The number of joints in the water service pipe is kept to a minimum.
- (d)
 - 1. If the water service pipe and sewer intersect, then a sleeve shall be used on the water service pipe extending five (5) feet on either side of the intersection.
 - 2. The sleeve shall be of material approved for water service pipe as established in 815 KAR 20:020.
 - 3. The sleeve shall be sealed on each end to prevent debris from entering the sleeve.

Section 4. Distribution. (1) The water supply shall be distributed through a piping system entirely independent of another piping system.

(2) Piping which has been used for a purpose other than conveying potable water shall not be used for conveying potable water.

(3) Nonpotable water may be used for flushing a water closet or urinal, if the water is piped in an independent system.

(a) If a dual water distribution system is used, the nonpotable water supply shall be durably and adequately identified.

- (b)
 - 1. An outlet on the nonpotable water distribution system used for a drinking or domestic purpose shall be permanently posted: DANGER - UNSAFE WATER.
 - 2. Each branch, fitting, or valve shall be identified by the phrase - "NONPOTABLE WATER" either by a sign or brass tag that shall be permanently affixed to the pipe, fitting, or valve.
 - 3. The identification marking shall not be concealed and shall be maintained by the owner.

(4) A backflow device or cross-connection control device shall be approved by the department.

(5) A combination stop and waste valve, cock, or hydrant shall not be installed in the underground water distribution system without the installation of an approved backflow preventer.

(6) A private water supply shall not be interconnected with a public water supply.

(7) Water used for cooling of equipment or in another process shall not be returned to the potable water system. The water shall be discharged into a drainage system through an air gap, or used for a nonpotable purpose as referenced in this section.

(8) Hose connections other than those intended for clothes washing machines, frost proof burial hydrants, and water heater drain valves shall be equipped with a vacuum breaker ASSE 1011 for areas not subject to freezing and a vacuum breaker ASSE 1019 for areas subject to freezing.

Section 5. Water Supply to Fixtures. (1) A plumbing fixture shall be provided with a sufficient supply of water for flushing to keep them in a sanitary condition.

(2) A water closet or pedestal urinal shall be flushed by means of an approved tank or flush valve.

(3) The tank or valves shall furnish at least a sufficient amount of water to thoroughly cleanse the surface area of a water closet, urinal, or similar fixture.

(4) If a water closet, urinal, or similar fixture is supplied directly from the water supply system through a flushometer or other valve, the valve shall be set above the fixture to prevent the possibility of polluting the potable water supply by back siphonage.

(5) The fixture shall have a vacuum breaker.

(6) A plumbing fixture, device or appurtenance shall be installed in a manner that shall prevent a possibility of a cross connection between the potable water supply system, drainage system, or other water system.

Section 6. Connections to Boilers. (1) A potable water connection to a boiler feed water system in which a boiler water conditioning chemical is introduced shall be made through an air gap, or provided with a reduced pressure principle backflow preventer located in the potable water line before the point where a chemical is introduced.

(2) A boiler shall be equipped with a check valve in the cold water supply to the boiler.

Section 7. Water Supply to Drinking Fountains. The orifice of a drinking fountain shall be provided with a protective cowl to prevent contamination of the potable water supply system.

Section 8. Sizing of Water Supply Piping.

(1) (a) The minimum size water service from the property line to the water heater shall be three-fourths (3/4) inch.

(b) The hot and cold water piping shall extend three-fourths (3/4) inch in size to the first fixture branch.

(c) More than three (3), one-half (1/2) inch fixture branches shall not be supplied from a one-half (1/2) inch pipe.

(2) (a) The schedule in this subsection shall be used for sizing the water supply piping to a fixture.

(b) The branch pipe to a fixture shall terminate not more than thirty (30) inches from the point of connection to the fixture and shall be brought to the floor or wall adjacent to the fixture.

(c) A concealed water branch pipe shall not be less than one-half (1/2) inch nominal pipe size.

Fixture Branches	Nominal Pipe Size (Inches)
Bath tubs	1/2
Combination sink and tray	1/2
Cupsidor	1/2
Drinking fountain	1/2
Dishwasher (domestic)	1/2
Kitchen sink (res.)	1/2
Kitchen sink (com.)	1/2 or 3/4 as required
Lavatory	1/2
Laundry tray	1/2
Sinks (service, slop)	1/2
Sinks flushing rim	3/4
Urinal (flush tank)	1/2
Urinal (direct flush type)	1/2 or 3/4 as required
Water closet (tank type)	1/2
Water closet (flush valve type)	1
Hot water boilers	3/4
Hose bibs	1/2
Wall hydrant	1/2
Domestic clothes washer	1/2
Shower (single head)	3/4

(3) Water hammer. In a building supply system in which a device or appurtenance is installed utilizing a quick acting valve that causes noise due to water hammer, a protective device, including an air chamber or approved mechanical shock absorber, shall be installed as close as possible to the quick acting valve causing the water hammer.

- (a) If a mechanical shock absorber is installed, the absorber shall be in an accessible place.
- (b) If a mechanical device is used, the manufacturer's specifications shall be followed as to location and method of installation.

Section 9. Water Supply Pipes and Fittings, Materials. (1) Water supply piping for a potable water system shall be as follows:

- (a) Galvanized wrought iron;
- (b) Galvanized steel;
- (c) Brass;
- (d) Types K, L, and M copper;
- (e) Cast iron;
- (f) Types R-K, R-L, and R-M brass tubing;
- (g) Fusion welded copper tubing produced and labeled as ASTM B447 and ASTM B251;
- (h) Seamless stainless steel tubing produced and labeled as ASTM A269 or ASTM A312;
- (i) Filament-wound reinforced thermosetting resin pipe produced and labeled as ASTM D2996 (red thread for cold water use and silver and green thread for hot and cold);
- (j) PE pipe produced and labeled as ASTM D2239 or ASTM F714;
- (k) PEX pipe produced and labeled as ASTM F876 for cold water and ASTM F877 for hot or cold water applications;
- (l) Pex-Al-Pex pipe produced and labeled as ASTM F1281;
- (m) Pe-Al-Pe pipe produced and labeled as ASTM F1282;

- (n) Copper tubing size PE produced and labeled as ASTM D2737 for water service, if installed with compression couplings;
- (o) PVC pipe produced and labeled as ASTM D1785;
- (p) CPVC pipe produced and labeled as ASTM D2846;
- (q) Schedule 80 CPVC pipe shall meet ASTM F441;
- (r) Schedule 80 CPVC solvent fittings shall meet ASTM F439;
- (s) Schedule 80 CPVC threaded fittings shall meet ASTM F437;
- (t) Schedule 80 CPVC pipe and fittings shall be installed using primer meeting ASTM F656 and solvent cement meeting ASTM F493;
- (u) PVC standard dimensional ratio (SDR) 21 and (SDR) 26 pipe produced and labeled as ASTM D2241;
- (v) Fusion welded PP products measuring one-half (1/2) inch to eighteen (18) inches in diameter which meet NSF Standards 61 and 14, and ASTM F2389, shall be approved. These pipe products shall be tested for compliance with the manufacturer's installation instructions;
- (w) Fusion welded high density PE pipe products which meet NSF Standards 61 and 14, and ASTM F3035 and F714, shall be approved for underground use. These pipe products shall be tested for compliance with the manufacturer's installation instructions;
- (x) Push-fit fitting systems which meet the ASSE Standard 1061. Except as established in 815 KAR 20:020, these systems are approved for above-ground use only using pipe sizes up to two (2) inches; or
- (y) PE-RT Piping meeting ASTM F2769.

(2) A plastic pipe or fitting shall bear the NSF seal of approval.

(3) PB pipe utilizing an insert fitting of brass or copper shall use a copper clamping ring.

(4) A PB hot and cold water connector to a lavatory, sink, or water closet shall be produced and labeled as ASTM D3309, and PB plastic pipe shall be produced and labeled as ASTM 2662 for a cold water application.

(5) A fitting shall be brass, copper, approved plastic, galvanized cast iron, or galvanized malleable iron. Piping or a fitting that has been used for another purpose shall not be used for the water distribution system.

(6) Each joint in the water supply system shall be made of a screw, solder, or plastic joint. A cast iron water pipe joint may be caulked, screwed, or machine drawn.

(7) If Type M copper pipe, Type R-M brass tubing, standard high frequency welded tubing or stainless steel tubing is placed within a concrete floor or passes through a concrete floor, it shall be wrapped with an approved material to permit expansion or contraction.

(8) PVC shall not be used below ground under a house or building. If a CPVC joint or connection is installed below ground under a house or building, the water distribution system shall be tested to at least 100 pounds per square inch before backfilling. The applicable requirements of 815 KAR 20:060 shall be met.

(9) The joint between ferrous piping and copper or copper-alloy piping shall be made with a dielectric fitting or other insulating fitting to prevent electrolysis.

Section 10. Temperature and Pressure Control Devices for Shower Installations. A temperature or pressure balance device to prevent a sudden unanticipated change in water temperature shall be installed to serve each shower compartment and shower-bath combination.

Section 11. Water Supply Control. (1) A main shutoff valve shall be provided near the curb, in or near the meter box or property line on the water service pipe. The main supply control valve shall be a full port valve and be accessible from within the occupied space and provided with a drip or drain valve. A pit or similar type installation shall not be used for a potable water supply shutoff valve.

(2) A pressure or gravity tank shall have its supply line valved at or near its source.

(3) A family unit in a two (2) family or multifamily dwelling shall have the unit controlled by an arrangement of shutoff valves which will permit the unit to be shut off without interfering with the cold water supply to another family unit or portion of the building.

(4) In a building other than a dwelling, a shutoff valve shall be installed to permit the water supply to the equipment to be isolated without interference with the supply to other equipment.

(5) A fixture or group of bath fixtures shall be valved and a lawn sprinkler opening shall be valved. In residential construction, each fixture, except a bathtub or shower, shall be valved individually or as a group of fixtures.

(6) A group of fixtures or a fixture group shall include two (2) or more fixtures adjacent to or near each other in the same room or back to back on a common wall.

(7) The cold water branch to a hot water storage tank or water heater shall be provided with a shutoff valve located near the equipment and serving this equipment. In residential dwellings, the shutoff valve shall be placed within three (3) feet of the water heater and be accessible from the accessible side of the water heater.

Section 12. Water Supply Protection. (1) A concealed water pipe, storage tank, cistern, or other exposed pipe or tank subject to freezing temperatures shall be protected against freezing. A water service shall be installed at least thirty (30) inches in depth.

(2) A relief device shall be installed on a pneumatic water system.

Section 13. Protection of a Private Water Supply or Source. A private water supply or source shall be protected from pollution. Approval shall be obtained from the division prior to using the private water supply or source.

Section 14. Tanks and Vats below Rim Supply. A tank or vat with potable water supply below the rim shall be subject to the following requirements:

(1) If a potable water outlet terminates below the rim of a tank or vat and the tank or vat has an overflow of diameter not less than given in the table in this subsection, the overflow pipe shall be provided with an air gap as close to the tank as possible;

Sizes of Overflow Pipes for Water Supply Tanks			
Maximum capacity of water supply line to tank	Diameter of Overflow pipe (inches ID)	Maximum capacity of water supply line to tank	Diameter of overflow pipe (inches ID)
0-50 gpm	2	400-700 gpm	5
50-150 gpm	2 1/2	700-1000 gpm	6
150-200	3	Over 1000 gpm	8

(2) The potable water outlet to the tank or vat shall terminate at a distance not less than one and one-half (1 1/2) times the height to which water can rise in the tank above the top of the overflow. This level shall be established at the maximum flow rate of the supply to the tank or vat, and with all outlets, except the air gap overflow outlet, closed; and

(3) The distance from the outlet to the high water level shall be measured from the critical point of the potable water supply outlet.

Section 15. Fire Protection Systems. Except if installing an NFPA 13D fire protection system in a one (1) or two (2) family dwelling, a fire protection system using water from the potable water distribution system shall be equipped with two (2) check valves, one (1) of which may be an alarm check valve.

Section 16. Conservation of water shall comply with the standards established in 815 KAR 20:070. (1 Ky.R. 485; eff. 3-12-1975; Am. 2 Ky.R. 457; eff. 4-14-1976; 3 Ky.R. 450; eff. 1-5-1977; 4 Ky.R. 190; 425; eff. 5-3-1978; Recodified from 401 KAR 1:090, 7-5-1978; 5 Ky.R. 163; eff. 10-4-1978; 7 Ky.R. 513; eff. 1-7-1981; 647; 849; eff. 6-3-1981; 9 Ky.R. 49; eff. 8-11-1982; 1242; eff. 6-1-1983; 10 Ky.R. 1013; eff. 3-31-1984; 11 Ky.R. 74; eff. 8-7-1984; 802; 1259; eff. 2-12-1985; 12 Ky.R. 436; eff. 11-12-1985; 1667; eff. 5-6-1986; 13 Ky.R. 1656; eff. 4-14-1987; 14 Ky.R. 636; eff. 11-6-1987; 1135; eff. 1-4-1988; 15 Ky.R. 605; 974; eff. 9-28-1988; 16 Ky.R. 904; eff. 1-12-1990; 2767; 17 Ky.R. 1100; eff. 8-22-1990; 2269; eff. 3-13-1991; 18 Ky.R. 2894; eff. 5-1-1992; 19 Ky.R. 816; eff. 11-9-1992; 2113; eff. 7-12-1993; 20 Ky.R. 3119; eff. 7-7-1994; 21 Ky.R. 1967; eff. 3-22-1993; 22 Ky.R. 800; eff. 12-7-1995; 23 Ky.R. 1757; 2739; eff. 1-9-1997; 24 Ky.R. 2465; eff. 7-13-1998; 25 Ky.R. 1187; eff. 2-18-1999; 2961; 26 Ky.R. 388; eff. 8-16-1999; 27 Ky.R. 2244; 2801; eff. 3-22-2001; 29 Ky.R. 1392; 1812; eff. 1-16-2003; 32 Ky.R. 369; 660; eff. 11-4-2005; 2371; 33 Ky.R. 411; eff. 9-1-2006; 3266; 4174; eff. 7-6-2007; 35 Ky.R. 2601; 36 Ky.R. 93; eff. 7-29-2009; 39 Ky.R. 2210; eff. 8-2-2013; 43 Ky.R. 466, 689; eff. 11-16-2016; 46 Ky.R. 1674,2436; eff. 6-2-2020.)

815 KAR 20:130 House sewers and storm water piping; methods of installation

RELATES TO: KRS 318.010, 318.015, 318.130, 318.150

STATUTORY AUTHORITY: KRS 198B.040(10), 318.130

NECESSITY, FUNCTION, AND CONFORMITY: KRS 318.130 requires the department to promulgate administrative regulations establishing the Kentucky State Plumbing Code to regulate plumbing, including the methods and materials that may be used in Kentucky for the construction of house sewers and storm water piping. This administrative regulation establishes the materials and methods of installation that may be used in the construction of house sewers or storm water piping.

Section 1. Independent System. (1) The drainage and plumbing system of a new building and of a new work installed in an existing building shall be separate and independent of other buildings except as otherwise established in this administrative regulation.

(2) A building shall have an independent connection with either a public or private sewer or sewer system.

Section 2. Exceptions. (1)(a) If a building stands in the rear of other buildings or on an interior lot and a sewer connection cannot be made available to the rear building through an adjoining alley, court, yard, or driveway, the sewer from the front building may be extended to the rear building and it shall be considered as one (1) sewer.

(b) The exception established in this subsection shall not apply to corner lots if a sewer connection is available from the street or alley or to a new or existing building that abuts a street or alley.

(2) A building sewer may serve additional buildings and still be considered as one (1) sewer if the additional buildings are:

(a) Used in conjunction with the primary building;

(b) Contained within the same deed as the primary building; and

(c) Restricted within the deed from being sold separately from the primary building.

Section 3. Connection with Private Sewage Disposal System. If a sewer is not available, the house drain from a building shall connect with an approved private sewage disposal system.

Section 4. Excavations. An excavation made for the installation of a house sewer shall be open trench work, and the trenches shall be kept open until the piping has been inspected, tested, and approved.

Section 5. Depth of Sewer at the Property Line. (1) The sewer at the property line shall be at a sufficient depth to properly serve a plumbing connection installed in the basement of a building.

(2) (a) A house sewer shall be laid on a grade of not less than one-eighth (1/8) inch nor more than one-fourth (1/4) inch per foot.

(b) A sewer shall have at least an eighteen (18) inch cover.

(c) Sewer piping installed under property subject to vehicular traffic (such as a driveway, parking lot, or similar location) shall have at least a twenty-four (24) inch cover unless:

1. Constructed of cast iron piping, schedule 40 or 80 PVC produced and labeled as ASTM D2665 or D1784, or schedule 40 or 80 ABS produced and labeled as ASTM D2661; and
 2. Encased in a minimum of six (6) inches of concrete on each side and the top. Pipe shall be covered to prevent direct contact with concrete.
- (d) A sewer shall be backfilled by hand and tamped six (6) inches above the piping or filled with six (6) inches grillage above the piping.
- (e) Each joint in cast iron and vitrified clay pipe shall be constructed to comply with 815 KAR 20:060, Sections 4 and 5.
- (f) If less than eighteen (18) inches of cover is available, a request for a variance shall be submitted to the division in writing.

Section 6. New House Sewer Connections. A house sewer installed where a private sewerage system has been discarded may connect to the house drain if the existing plumbing system meets the State Plumbing Code.

Section 7. Materials for House Sewers. A house sewer or combined sewer shall be made of:

- (1) Extra heavy cast iron pipe;
- (2) Service weight cast iron;
- (3) Vitrified clay;
- (4) Concrete;
- (5) Coextruded composite PVC pipe produced and labeled ASTM F1488;
- (6) PVC or ABS plastic pipe Schedules 40 and 80;
- (7) Cellular core PVC produced and labeled as ASTM F891;
- (8) Cellular core ABS produced and labeled as ASTM 628 or ASTM F1488;
- (9) Truss pipe;
- (10) Extra heavy SDR 35 pipe;
- (11) Type PS 46, PVC in sizes four (4) inches through fifteen (15) inches produced and labeled as ASTM F789;
- (12) PVC ribbed pipe produced and labeled as ASTM F794; or
- (13) PE produced and labeled as ASTM F714.

Section 8. Material for Storm Sewers Inside Buildings. (1) A storm sewer inside a building extending to a point two (2) feet outside a building in sizes eight (8) inches and smaller shall be made of:

- (a) Cast iron pipe;
 - (b) Aluminum; or
 - (c) Schedule 40 ABS or PVC DWV pipe or PVC pipe produced and labeled as ASTM F1488.
- (2) A storm sewer in a size of ten (10) inches or larger shall be made of:
- (a) Cast iron;
 - (b) Aluminum;
 - (c) Schedule 40 ABS or PVC DWV pipe;
 - (d) SDR 35;
 - (e) Vitrified clay or concrete conforming to appropriate commercial specifications with approved joints; or
 - (f) PE pipe produced and labeled as ASTM F714.

(3) Primary and secondary roof drains shall comply with the requirements established in this subsection.

- (a)
 - 1. Roof drains shall have strainers extending not less than four (4) inches above the surface of the roof immediately adjacent to the roof drain.
 - 2. Strainers shall have an available area not less than one and one-half (1 1/2) times the area of the conductor or leader to which the drain is connected.
- (b) Roof drain strainers for use on sun decks, parking decks, and similar areas that are normally serviced and maintained, may be of the flat surface type, installed level with the deck, with an available inlet area not less than two (2) times the area of the conductor or leader to which the drain is connected.
- (c) Secondary (emergency) roof drains or scuppers shall be provided where the roof perimeter construction allows ponding if the primary roof drains become blocked.
- (d) Separate systems required.
 - 1. Secondary roof drain systems shall have piping and point of discharge separate from the primary system.
 - 2. Discharge shall be above grade plane in a location that would normally be observed by the building occupants or maintenance personnel.
- (e) Primary and secondary drains shall be sized in accordance with Section 11 of this administrative regulation.

Section 9. Change of Direction. A change in direction of a sewer shall be made only with:

- (1) Long curves;
- (2) Forty-five (45) degree wyes;
- (3) Half wyes;
- (4) Quarter, sixth, eighth or sixteenth bends; or
- (5) Sanitary tees installed on their back or on their sides. If installed, sanitary tees shall be at an angle of not more than forty-five (45) degrees.

Section 10. Size of House Sewers and Horizontal Branches. (1) The minimum size of a house sewer shall not be less than four (4) inches nor less than that of the house drain.

- (2) A house sewer receiving a branch shall be sized in the same manner as a house drain.
- (3) The house drains shall be installed in accordance with 815 KAR 20:090.

Section 11. Size of Storm Systems. (1) The required size of a storm sewer shall be determined on the basis of the total drained area in horizontal projection in accordance with the table in subsection (4) of this section.

- (2) A storm sewer shall not be laid parallel to or within two (2) feet of a bearing wall.
- (3) The storm sewer shall be laid at a sufficient depth to protect it from freezing
- (4)

Diameter of pipe - inches	Maximum drained roof area square feet*	
	Slope 1/8 in. fall to 1 ft.	Slope 1/4 in. fall to 1 ft.
3	N/A	1,160
4	1,880	2,650
5	3,340	4,720
6	5,350	7,550
8	11,500	16,300
10	20,700	29,200
12	33,300	47,000
15	59,500	84,000

*The calculations in this table are based on a rate of rainfall of four (4) inches per hour

Section 12. Combined Storm and Sanitary Sewer System. (1) If a combined sewer system is used, the required size of the house drain or house sewer shall be determined by multiplying the total number of fixture units carried by the drain or sewer by the conversion factor corresponding to the drained area, and the total fixture units, adding the product to the drained area and applying the sum from the table for storm water sewers in Section 11 of this administrative regulation.

(2) A combined house drain or house sewer shall not be less than four (4) inches in diameter, and a combined house drain or house sewer shall not be smaller in size than that required for the same number of fixture units or for the same roof area in separate systems.

(3)

CONVERSION FACTORS FOR COMBINED STORM AND SANITARY SYSTEM								
Number of Fixture Units on Sanitary System								
Drained roof area in square feet	Up to 6	7 to 18	19 to 36	37 to 60	61 to 96	97 to 144	145 to 216	217 to 324
Up to 120	180	105	60	45	30	22	18	15
121 to 240	160	98	57	43	29	21	17.6	14.7
241 to 480	120	75	50	39	27	20	16.9	14.3
481 to 720	75	62	42	35	24	18	15.4	13.2
721 to 1,080	54	42	33	29	20	15	13.6	12.1
1,081 to 1,620	30	18	16	15	12	11.5	11.1	10.4
1,621 to 2,430	15	12	11	10.5	9.1	8.8	8.6	8.3
2,431 to 3,645	7.5	7.2	7.0	6.9	6.6	6.5	6.4	6.3
3,646 to 5,460	2.0	2.4	3.0	3.3	4.1	4.2	4.3	4.4
5,461 to 8,190	0	2.0	2.1	2.2	2.3	2.4	2.5	2.6
8,191 to 12,285	0	0	2.0	2.1	2.1	2.2	2.3	2.3
12,286 to 18,420	0	0	0	2.1	2.1	2.1	2.2	2.2
18,421 to 27,630	0	0	0	0	2.0	2.1	2.2	2.2
27,631 to 40,945	0	0	0	0	0	2.0	2.1	2.2
40,946 to 61,520	0	0	0	0	0	0	2.0	2.1
Over 61,520	0	0	0	0	0	0	0	2.0

(4)

NUMBER OF FIXTURE UNITS ON SANITARY SYSTEMS								
Drained roof area in square feet	325 to 486	487 to 732	733 to 1,098	1,099 to 1,644	1,645 to 2,466	2,467 to 3,702	3,703 to 5,556	Over 5556
Up to 120	12	10.2	9.2	8.4	8.2	8.0	7.9	7.8
121 to 240	11.8	9.9	9.1	8.3	8.1	8.0	7.9	7.8
241 to 480	11.5	9.7	8.8	8.2	8.0	7.9	7.8	7.7
481 to 720	10.8	9.2	8.6	8.1	7.9	7.9	7.8	7.7
721 - 1,080	10.1	8.7	8.3	8.0	7.8	7.8	7.7	7.6
1,081 - 1,620	9.8	8.4	8.1	7.9	7.7	7.7	7.6	7.5
1,621 - 2,430	8.0	7.9	7.8	7.7	7.6	7.5	7.4	7.4
2,431 - 3,645	6.2	6.3	6.4	6.4	6.8	7.0	7.1	7.2
3,646 - 5,460	4.5	4.7	5.0	5.1	6.1	6.4	6.9	6.9
5,461 - 8,190	2.8	3.2	3.7	4.6	5.0	5.6	6.2	6.4
8,191 – 12,285	2.4	2.5	2.6	2.7	3.5	4.5	5.2	5.6
12,286 - 18,420	2.3	2.3	2.4	2.6	2.6	3.2	4.2	4.7
18,421 - 27,630	2.2	2.3	2.3	2.4	2.5		2.8	3.1
27,631 - 40,945	2.2	2.2	2.2	2.2	2.2		2.3	2.4
40,946 - 61,520	2.1	2.1	2.1	2.1	2.1		2.1	2.1
Over 61,520	2.0	2.0	2.0	2.0	2.0		2.0	2.0

(5) For a building constructed after August 1, 1996, each plumbing fixture or opening connecting to a combination sanitary and storm sewer system shall either:

- (a) Be installed above the elevation of the cover of the nearest manhole serving the main; or
- (b) Discharge through a sewage ejector to the combined sewer system at an elevation high enough to prevent flooding of the building.

Section 13. Storm Sewers and House Sewers in Undisturbed or Filled Ground. (1) A house sewer laid in undisturbed ground shall be laid on at least four (4) inches of pea gravel, sand, or other approved grillage as defined in 815 KAR 20:010.

(2) A storm sewer laid in undisturbed ground shall not require grillage.

(3) A storm sewer or house sewer laid in filled ground shall be embedded to the lower quadrant with at least a four (4) inch concrete pad below the invert, or other equivalent support approved by the department.

(4) A support filled in ground shall be on a ten (10) foot center to a solid footing, either undisturbed earth or rock.

(5) A house sewer constructed of flexible thermoplastic sewer piping shall be installed with at least six (6) inches of gravel on the bottom, top, and sides of the piping.

Section 14. Drainage Below Sewer Level (Public). In a public building in which the whole or part of the building drain and plumbing system lies below the level of a main sewer, sewage and waste shall be lifted by a device that complies with Sections 16 and 17 of this administrative regulation and discharged into the building sewer.

Section 15. Drainage Below Sewer Level (Residential). (1) In a residential building in which the sewer level is above the basement floor, waste water shall be lifted by means of an approved sump pump appropriate for that installation.

(2) The sump pit shall:

(a) Be gas and air tight; and

(b) Be constructed of:

1. Poured or precast concrete;
2. Approved fiberglass; or
3. PE material.

(3) The sump pit shall be provided with a two (2) inch vent, which may also act as a waste and vent for a laundry tray.

(4) The pump discharge piping shall be discharged into a two (2) inch waste pipe extended inside the building to a height at least twelve (12) inches above the outside grade plane.

(5) The sump pit shall be provided with a tight fitting concrete cover.

(6) (a) On the outside of the building, the waste piping shall connect into a four (4) inch by two (2) inch sanitary tee, which shall connect into a four (4) inch P trap and then into the sanitary sewer.

(b) The four (4) inch by two (2) inch sanitary tee shall be extended at least two (2) inches above the finished grade plane and shall be provided with a ventilated cap.

Section 16. Sumps and Receiving Tanks. (1) A subsoil drain shall discharge into an air tight sump or receiving tank located to receive the sewage by gravity.

(2) The sewage shall be lifted and discharged into the house sewer by a pump or ejector.

(3) Sewage sumps shall be a minimum twenty four (24) inches in diameter and no less than twenty four (24) inches in depth.

(4) A system that relies solely on a pump shall be equipped with both an audible and visual alarm to be placed within the occupied space.

(5) The sump shall automatically discharge.

Section 17. Ejectors, Vented. (1) A sewage ejector serving a residential installation shall be vented with a two (2) inch vent.

(2) (a) Except as established in paragraph (b) of this subsection, an ejector serving a commercial or industrial installation shall be vented with a three (3) inch vent.

(b) 1. If a three (3) inch vent stack is serving a fixture that empties into the ejector pit and is located within twenty-five (25) feet of the pit, the ejector may be revented with a two (2) inch vent back to the three (3) inch vent stack.

2. The ejector vent shall not be smaller than that recommended by the manufacturer of the pump.

(3) A portion of the building drainage system that is above the cover of the manhole serving the main that can flow by the gravity to a sewer shall be installed for gravity flow to the combined sanitary and storm sewer, except for a system designed otherwise by a licensed professional engineer.

Section 18. Ejector Power: Motors, Compressors, and Air Tanks. (1) A motor, air compressor, or air tank shall be located so that it shall be open for inspection and repair at all times.

(2) An air tank shall be proportioned to furnish sufficient air at suitable pressure to the ejector to completely empty the sump or storage tank with the compressor not operating.

(3) The end pressure in the tank shall not be less than two (2) pounds for each foot of height through which sewage is raised.

Section 19. Ejectors for Subsoil Drainage. (1) If a subsoil catch basin is installed below the sewer level, an automatic ejector shall be used.

(2) The ejector or a device raising subsoil water shall discharge into a properly trapped fixture or into a storm water drain.

Section 20. Drainage of Yards, Areas, Roofs, and Traps. (1) A roof, paved area, court, or courtyard shall be drained into:

- (a) A storm water system;
- (b) A combined sewerage system; or
- (c) A surface drainage area unless prohibited by the local health department or sewer district.

(2) A yard, roof, paved area, court, or courtyard shall not be drained into a sewer intended for sewage only.

(3) Traps.

- (a) If a drain is connected to a combined sewerage system, it shall be trapped.
- (b) If a roof leader, conductor, or gutter opening is located more than ten (10) feet from a window, scuttle, or air shaft, a trap shall not be required.
- (c) A trap shall be set below the frost line or on the inside of the building.
- (d) If a drain is not connected to a combined sewer, a trap shall not be required.

Section 21. Size of Rain Water Leader. An inside leader shall not be less size than as established in the following table:

Area of Roof (In Square Feet)	Leader, Diameter (Inches)
Up to 90	1 1/2
91 to 270	2
271 to 810	3
811 to 1,800	3 1/2
1,801 to 3,600	4
3,601 to 5,550	5
5,501 to 9600	6

Section 22. Inside Conductors or Roof Leaders. (1) If a conductor or roof leader is placed within the walls of a building, or in an interior court or ventilating pipe shaft, it shall be constructed of:

- (a) Cast iron pipe;
- (b) Galvanized wrought iron;
- (c) Galvanized steel;
- (d) Copper;
- (e) Schedule 40 ABS or PVC DWV pipe; or
- (f) Reinforced thermosetting resin pipe produced and labeled as ASTM F1113 (red and silver thread).

(2) (a) Except as established in paragraph (b) of this subsection, PVC or ABS pipe and fittings shall be limited to buildings in which the conductor does not exceed forty-five (45) feet in height, measured from the grade plane as defined by the Kentucky Building Code, 815 KAR 7:120, or Kentucky Residential Code, 815 KAR 7: 125, and continuing through the vertical distance of the building to a maximum height of forty-five (45) feet.

(b) PVC or ABS pipe and fittings may be installed in a building in which the conductor exceeds forty-five (45) feet in height if the installation complies with all of the requirements established in this section.

(c) The use of PVC and ABS piping shall be limited to Schedule 40 or 80 produced and labeled as ASTM D2665 and D1784 for PVC piping and ASTM D2661 for ABS piping.

(d) The installation of the PVC or ABS pipe and fittings shall be made in compliance with the manufacturer's recommendations, which shall be made available to the inspector.

(e) Firestop systems shall be inspected in accordance with ASTM E2174 by an inspection agency approved by the department.

Section 23. Outside Conductors. (1) If an outside sheet metal conductor or downspout is connected to a house drain, it shall be connected by means of cast iron pipe extending vertically at least one (1) foot above the grade plane.

(2) If the downspout runs along a public driveway without a sidewalk, it shall be placed in a niche in the walk, protected by wheel guards, or enter the building through the wall at a forty-five (45) degree slope at least twelve (12) inches above the grade plane.

Section 24. Defective Conductor Pipes. If an existing sheet metal conductor pipe within the walls of a building becomes defective, the conductor shall be replaced by one that conforms to this administrative regulation.

Section 25. Vent Connections with Conductors Prohibited. (1) A conductor pipe shall not be used as a soil, waste, or vent pipe.

(2) A soil, waste, or vent pipe shall not be used as a conductor.

Section 26. Overflow Pipes. An overflow pipe from a cistern, supply tank, expansion tank, or drip pan shall connect indirectly with a house sewer, house drain, soil pipe, or waste pipe.

Section 27. Subsoil Drains. A subsoil drain below sewer level shall discharge into a sump or receiving tank and shall be automatically lifted and discharged into the storm drainage system or upon the ground outside the building it serves.

Section 28. Approvals of New Sewer Connections to Existing Buildings. If the local health department or sanitary sewage system board, plant district, or treatment plant owner prohibits the discharge of a basement floor drain or other apparatus into the sanitary sewer system, an existing basement floor drain or sump pump apparatus shall comply with the construction requirements of this administrative regulation and be inspected prior to the approval of a connection for a new sewer line. (Recodified from 401 KAR 1:100, 7-5-1978; Am. 5 Ky.R. 164; eff. 10-4-1978; 8 Ky.R. 362; eff. 1-6-1982; 10 Ky.R. 1016; eff. 3-31-1984; 12 Ky.R. 1675; eff. 5-6-1986; 13 Ky.R. 959; eff. 12-2-1986; 14 Ky.R. 1142; eff. 1-4-1988; 16 Ky.R. 911; eff. 1-12-1990; 2779; 17 Ky.R. 1108; eff. 8-22-1990; 18 Ky.R. 2725; eff. 4-3-1992; 19 Ky.R. 822; eff. 11-9-1992; 1659; eff. 3-12-1993; 2742; 20 Ky.R. 309; eff. 8-6-1993; 21 Ky.R. 1974; eff. 3-22-1995; 22 Ky.R. 2339; eff. 8-1-1996; 23 Ky.R. 2625; 2994; eff. 2-10-1997; 24 Ky.R. 962; eff. 12-15-1997; 27 Ky.R. 231; 773; eff. 9-11-2000; 33 Ky.R. 3273; 4180; eff. 7-6-2007; 35 Ky.R. 2608; 36 Ky.R. 99; eff. 7-29-2009; 41 Ky.R. 179; eff. 9-24-2014; 42 Ky.R. 133; eff. 11-6-2015; 43 Ky.R. 624; eff. 1-6-2017; 46 Ky.R. 1682, 2442; eff. 6-2-2020.

815 KAR 20:150. Inspection and tests.

RELATES TO: KRS 318.090, 318.130, 318.134, 318.140, 318.160, 318.170

STATUTORY AUTHORITY: KRS 198B.040(10), 318.130

NECESSITY, FUNCTION, AND CONFORMITY: KRS 318.130 requires the department to promulgate an administrative regulation establishing the Kentucky State Plumbing Code. KRS 318.160 requires a person who constructs, installs, or extensively alters any plumbing, sewerage, or water supply system of any public building or establishment to obtain approval of the department in writing. This administrative regulation establishes the requirements for the tests and inspections that are necessary in order to ensure compliance with 815 KAR Chapter 20, the Kentucky State Plumbing Code.

Section 1. Required Inspections and Tests. (1) Required inspections. The department shall inspect the following to ensure compliance with the code:

- (a) The water distribution system;
- (b) The soil, waste, and vent system;
- (c) The fixtures and fixture traps;
- (d) Appurtenances; and
- (e) All connections in a plumbing system.

(2) Required tests. Tests shall be made separately or as follows:

- (a) The house sewer and its branches from the property line to the house drain;
- (b) The house drain including its branches;
- (c) The soil, waste, and vent system;
- (d) Inside rain water conductors; and
- (e) The final inspection and air test which shall include the complete plumbing system as required by Section 3(2) of this administrative regulation, exclusive of the house sewer.

(3) Rough-in inspection.

- (a) The plumbing system shall not be covered until it has been inspected, tested, and approved.
- (b) A rough-in inspection shall be conducted prior to the covering or concealment of the plumbing system.
- (c) If any part of a plumbing system is covered or concealed before being inspected, tested, and approved, it shall be uncovered, or unconcealed and tested as required.

(4) Condemned buildings. In buildings condemned by other authorities because of unsanitary conditions of the plumbing system, necessary alterations shall be considered a new plumbing system.

(5) Tests of alterations, extensions, or repairs. Any alterations, repairs, or extensions that require more than ten (10) feet of soil, waste, or vent piping shall be inspected and tested as required by Section 3(2) of this administrative regulation.

Section 2. Permit Holder Requirements. The person procuring the plumbing permit shall:

- (1) Furnish all equipment, material, and labor necessary for inspections and tests;
- (2) Notify the department representative and request a rough-in inspection for the plumbing system prior to the plumbing system being concealed or covered within the floors or walls of a building; and
- (3) Notify a department representative and request a final inspection and air test upon completion of the installation.

Section 3. Testing of Systems. (1) The water distribution system, as well as the water service, shall be:

- (a) Tested with air or water under a pressure of not less than the maximum working pressure under which it is to be used; and
 - (b) Free from leaks.
- (2) (a) Except as provided in subsection (3) of this section, a water test shall be performed:
- 1. On the entire soil, waste, and vent system; or
 - 2. In sections.
- (b) If it is applied to the entire system, all openings shall be closed, except the highest opening and the system shall be filled with water to the point of overflow.
- (c) If the system is tested in sections, each opening shall be tightly plugged, except the highest opening and it shall be tested with not less than a ten (10) foot head of water. In testing successive sections, at least the upper ten (10) feet of the preceding section shall be retested.
- (3) In lieu of a water test, an air pressure test may be used by attaching an air compressor or test apparatus to any suitable opening. All other inlets and outlets to the system shall be closed, forcing air into the system until there is a uniform pressure of five (5) pounds per square inch (PSI). The pressure shall be maintained for fifteen (15) minutes.
- (4) After the plumbing fixtures have been set and their traps filled with water and before the building is occupied, the final air test shall test the entire soil, waste, and vent system including the fixtures and appurtenances, other than a house sewer, by connecting an air machine to any suitable opening or outlet and applying air pressure equivalent to a one (1) inch water column. It shall be maintained for at least a fifteen (15) minute period. If there are no leaks or forcing of trap seals as may be indicated by the functioning of a drum, float, or water column, the system shall be determined as airtight.
- (5) A garage drainage system shall be tested in the same manner as the soil, waste, and vent system.
- (6) A house sewer shall be tested by a water, air, or smoke test. A four (4) inch test tee or Y connection shall be provided at the property line for testing.
- (7) The department may require the removal of any clean-outs to ascertain if the pressure has reached all parts of the system
- (8) A building sewer not drained by gravity shall have a minimum of twenty-four (24) inches of cover and shall be tested with five (5) pounds per square inch for a period of fifteen (15) minutes.
- (9) Inside rain water conductors shall be tested with water, air, or smoke test.

Section 4. Defective Work. If an inspection or a test indicates defective work or material, it shall be replaced and the inspection and the test repeated.

Section 5. Testing Defective Plumbing. An air test shall be used in testing the condition of a plumbing system if there is reason to believe it has become defective.

Section 6. Certificate of Approval. The department shall issue a certificate of approval upon the satisfactory completion and final test of the plumbing system. (PC-11-1; 1 Ky.R. 487; eff. 3-12-1975; 2 Ky.R. 459; 3 Ky.R.362; eff. 9-1-1976; Recodified from 401 KAR 1:110, 7-5-1978; 11 Ky.R. 77; eff. 8-7-1984; 20 Ky.R. 1394; eff. 1-10-1994; 27 Ky.R. 234; 776; eff. 9-11-2000; 33 Ky.R. 3277; 4183; eff. 7-6-2007; 46 Ky.R. 1686, 2446; eff. 6-2-2020.)

815 KAR 20:170. Manufactured home and mobile home community waste systems, water distribution, and connections.

RELATES TO: KRS 318.130, 318.150

STATUTORY AUTHORITY: KRS 198B.040(10), 318.130

NECESSITY, FUNCTION, AND CONFORMITY: KRS 318.130 requires the department to promulgate administrative regulations establishing the Kentucky State Plumbing Code to regulate plumbing. This administrative regulation establishes the requirements for manufactured home and mobile home community waste systems and connections, water distribution and connections, and specifies the materials and the methods that shall be used in installing the necessary plumbing to serve manufactured homes and mobile homes.

Section 1. Sewers. (1) The main and branch sewers for the connections of manufactured homes and mobile homes shall be laid at a uniform grade of no less than one-eighth (1/8) of an inch per foot. All joints shall be water tight.

(2) Clean-outs shall be provided at intervals not to exceed 100 feet for main and branch sewers in sizes six (6) inches and smaller.

(3) The clean-outs shall be extended to the grade with cast-iron soil pipe or schedule 40 ABS or schedule 40 PVC piping and shall be provided with a clean-out plug.

(4) A four (4) inch concrete pad, eighteen (18) inches square, shall be provided around each clean-out.

(5) All main and branch sewers eight (8) inches and larger shall not require clean-outs but shall require standard manholes at intervals not to exceed 400 feet as well as in all changes in direction.

(6) Each manufactured home and mobile home shall be provided with a four (4) inch sewer.

(7) A three (3) inch waste connection shall be provided and extended one (1) inch above the grade using a three (3) inch standard female thread.

(8) A four (4) inch concrete pad twenty-four (24) inches square shall be provided around the waste opening.

(9) A three (3) inch screw plug shall be fastened by a chain to the concrete pad which shall be used if the manufactured home or mobile home opening is not in use.

(10) The waste pipe connection between the manufactured home or mobile home and the sewer waste opening shall be a waterproof connection constructed of either cast-iron, schedule 40 steel pipe, copper pipe, or schedule 40 ABS or schedule 40 PVC piping.

(11) All branch sewers receiving waste from more than one (1) manufactured home or mobile home shall be sized as established in the following table:

Number of Manufactured Homes/Mobile Homes	Branch Sewer Size (in inches)
1 to 10	4
11 to 20	5
21 to 50	6
51 to 150	8
151 to 300	10

Section 2. Individual Residential Manufactured Homes and Mobile Home Waste System and Connection. (1) An individual residential manufactured home or mobile home shall either be connected to a municipal sewer system or to an approved private sewage disposal system in accordance with this section.

(2) Each manufactured home and mobile home shall be provided with at least a three (3) inch waste connection to the house sewer.

(3) All piping that does not have at least an eighteen (18) inch cover shall be cast-iron pipe.

(4) Waste connections between the permanent piping and the manufactured home or mobile home waste connection shall be a waterproof connection constructed of either cast-iron, schedule 40 steel pipe, copper pipe, or schedule 40 ABS or PVC piping.

Section 3. Water Distribution and Connections to Manufactured Homes and Mobile Homes. (1) An adequate and safe water supply shall be provided to each manufactured home and mobile home.

(2) All materials, including the pipe and fitting used for a connection, shall conform with the code.

(3) An individual water connection shall be provided at an appropriate location for each manufactured home and mobile home space.

(a) The connection shall consist of a riser terminating at least four (4) inches above the ground with a minimum two (2), three-fourths (3/4) inch valve.

(b) A frost proof hydrant shall be provided and accessible for lawn watering and fire control outlets with screw connection for the following:

1. One (1) valve outlet for the manufactured home or mobile home water system; and

2. One (1) valve outlet for lawn watering and fire control.

(c) The ground surface around the riser pipe shall be graded to divert surface drainage.

(d) The riser pipe shall be encased in an eight (8) inch vitrified clay pipe or an equivalent with the intervening space filled with an insulating material to protect against freezing.

(e) An insulated cover shall encase both valve outlets, but not prevent connection to the manufactured home or mobile home during freezing weather.

(f) A shutoff valve may be placed below the frost depth on the water service line, but this shutoff valve shall not be a stop-and-waste cock.

(4) The water line shall be the size established by the following table when installing water service for a manufactured home or mobile home community:

Number of Manufactured Homes/Mobile Homes	Water Line Size (in inches)
1 to 2	3/4
3 to 6	1
7 to 12	1 1/4
13 to 20	1 1/2
21 to 50	2
51 to 100	3
101 to 300	4

(PC-13-1; 1 Ky.R. 488; 1350; eff. 6-11-1975; 3 Ky.R. 705; eff. 7-7-1977; Recodified from 401 KAR 1:130, 7-5-78; Am. 17 Ky.R. 2895; eff. 5-3-91; TAm eff. 8-9-2007; 35 Ky.R. 2612; 36 Ky.R. 102; eff. 7-29-2009; 46 Ky.R.1689, 2447; eff. 6-2-2020.)

815 KAR 20:180 Special connections

RELATES TO: KRS 318.010, 318.130

STATUTORY AUTHORITY: KRS 198B.040(10), 318.130

NECESSITY, FUNCTION, AND CONFORMITY: KRS 318.130 requires the department to promulgate an administrative regulation establishing the Kentucky State Plumbing Code regulating plumbing, including the methods and materials that may be used in Kentucky. This administrative regulation establishes requirements regarding waste, other than sanitary wastes.

Section 1. Laundries. (1) Commercial Laundry Wastes. Waste from commercial and institutional washing machines and extractors shall not discharge into an open trench, unless the trench is:

- (a) Constructed of a material resistant to alkaline waste; and
- (b) Drained into at least a four (4) inch trap, with a full-size vent.

(2) Semi-commercial Laundries (Automatic).

- (a) Waste from semi-commercial washing machines shall discharge into a four (4) inch waste line for washing machines only.
- (b) The waste line shall have a full-size vent and the base of the stack shall be washed by either a washing machine or starch sink.
- (c) A four (4) inch trap shall be provided in the waste line to serve not more than two (2) washing machines.
- (d) Floor drains may be placed in the waste line if:
 - 1. The washing machines are the pump type; and
 - 2. A stand pipe is placed for each washing machine to at least two (2) inches above the flood level rim of the washing machine.
- (e) Each four (4) inch trap shall constitute four (4) fixture units.
- (f) A washing machine shall not discharge into a trench.

Section 2. Washing Machines, Automatic, Residential. (1) New Buildings.

- (a) An automatic washing machine installed in a new building shall:
 - 1. Have a two (2) inch trap; and
 - 2. Be vented in accordance with 815 KAR 20:080.

(b) The trap shall be installed twelve (12) inches above the floor with a two (2) inch stand pipe extended to at least two (2) inches above the flood level rim of the washing machine.

(2) Existing Buildings.

- (a) An automatic washing machine installed in an existing building shall be connected to the house sewer by a four (4) inch P-trap. The trap shall:
 - 1. Be placed on the outside of the building on the opposite side of the wall of the washing machine;
 - 2. Have a vented cover extending three (3) inches above the grade line; and
 - 3. Have a four (4) inch by two (2) inch tee installed in the inlet side of the trap with a two (2) inch waste pipe extending into the building through the floor to the height of the washing machine.
- (b) All waste piping shall conform with 815 KAR 20:080.

Section 3. Air Conditioning Equipment. (1) Air conditioning equipment installed with a water supply and waste shall conform with 815 KAR 20:090, Sections 28 and 31.

- (2) (a) Evaporative cooler, air washer, air handling, or similar air conditioning equipment shall not have any drain pipe directly connected to any soil, waste, or vent pipe. The evaporative cooler, air washer, air handling, or similar air conditioning equipment shall be drained by means of indirect waste pipe.

- (b) The indirect waste shall discharge through an air gap or air break into an open floor sink, floor drain, or other approved type receptor which is properly connected to the drainage system, except that an air gap shall be required if the indirect waste pipe may be under vacuum.
- (3) The condensate or waste pipe from an air conditioning unit shall be classified as a plumbing fixture only if directly connected to the plumbing system.

Section 4. Garage Sand Trap. A garage sand trap shall:

- (1) Be constructed of concrete with a heavy cover or grate;
- (2) Be at least two (2) feet by four (4) feet;
- (3) Have sufficient depth so that there is at least a ten (10) inch vertical distance between the bottom of the outlet ell and the bottom of the trap; and
- (4) Installed with a four (4) inch vent.

Section 5. Inflammable Waste. (1) Liquid waste from buildings using gasoline, benzene, naphtha, or other inflammable oils or compounds shall discharge into a separator before it enters a sanitary sewer.

- (2) The waste line receiving the waste shall be trapped and vented as established in 815 KAR 20:080 and 20:090.
- (3) The separator shall be installed with a three (3) inch vent.

Section 6. Hot Water, Steam Blowoffs or Exhaust. Before entering the house drain or sewer, hot water or steam or exhaust blowoffs shall discharge into a tank or basin with an airtight cover and a four (4) inch vent independent of any other venting system.

Section 7. Stable Manure Pits. Before entering the house sewer, all liquid waste from barns, stable manure pits, and stable yard drains shall discharge through a separator.

Section 8. Pedicure Chairs. (1) A two (2) inch open receptacle may receive the discharge from up to two (2) pedicure chairs. Three (3) to six (6) chairs shall have a minimum of a three (3) inch open receptacle.

(2) A branched tail piece discharge for a pump-type pedicure chair may be used in an existing location only after approval of the division.

(3) If the water inlet for a pedicure chair is below the flood level rim or is equipped with a spray hose, it will be treated as a high hazard and require a reduced pressure principle backflow preventer on both the hot and cold supply.

(PC-14; 1 Ky.R. 488; eff. 3-12-1975; Recodified from 401 KAR 1:140, 7-5-1978; 10 Ky.R. 457; eff. 11-2-1983; 17 Ky.R. 2896; eff. 5-3-1991; 32 Ky.R. 375; 666; 11-4-2005; 46 Ky.R. 1691; eff. 6-2-2020.)

815 KAR 20:191. Minimum fixture requirements.

RELATES TO: KRS 58.200, 162.062, 318.160

STATUTORY AUTHORITY: KRS 198B.040(10), 318.130

NECESSITY, FUNCTION, AND CONFORMITY: KRS 318.130 requires the to promulgate administrative regulations establishing the Kentucky State Plumbing Code regulating the construction, installation, and alteration of plumbing and plumbing fixtures and appliances, house sewers and private water supplies, and[including] the methods and materials that may be used in Kentucky. This administrative regulation establishes the minimum plumbing fixture requirements for buildings in Kentucky.

Section 1. General Requirements

- (1) In a building accommodating males and females, it shall be presumed that the occupants will be equally divided between males and females, unless otherwise denoted on the plan application documents.
- (2) The occupancy load factor used to determine the total number of plumbing fixtures required in a building shall be the load denoted in the Kentucky Building Code, incorporated by reference in 815 KAR 7:120.
- (3) All types of buildings shall be provided with toilet rooms on each level or floor, unless:
 - (a) Separate facilities on each level or floor are unnecessary; and
 - (b) Toilet rooms on every other level or floor shall be sufficient.
- (4) Unisex Facilities in Historic Buildings. A building or structure that is listed in the National Register of Historic Places or designated as historic under Kentucky statute may provide the required number of plumbing fixtures in unisex facilities if the overall occupant load is 100 persons or less, except as required in swimming pool bathhouses, park services buildings, and bathhouses in Group B, public garages in Group S-2, Group E buildings, dormitories in Group R-2, Group I-2 buildings, and Group I-3 buildings
- (5) Unisex facilities in historic buildings permitted by this section shall not be required to provide urinals.
- (6) Toilet rooms for males, females, and unisex shall be clearly marked.
- (7) Upon written request, the department shall permit the temporary use of a mobile facility in accordance with this administrative regulation. The written request shall be submitted to the division [of Plumbing] and shall include the:
 - (a) Name of the owner;
 - (b) Address of the location of the building being served by the mobile facilities; and
 - (c) Dates for which the mobile facilities are to be used.
- (8) Water closet type. All water closets in public restrooms shall be of an elongated bowl type with a split open front seat.
- (9) Service sinks.
 - (a) One (1) service sink shall be required on each floor of a public building unless otherwise approved by the department.
 - (b) A request for exemption of a service sink shall be submitted in writing to the division.
 - (c) The division shall respond in writing to the requester either granting or denying the exemption request.
 - (d)
 1. The division shall determine whether to grant or deny the exemption request based upon if the request increases the sanitation risk to the building.
 2. The division's decision shall be made on a case-by-case basis.
 3. The division shall consider factors such as:
 - a. If the building requires the mopping of floors, cleaning of surfaces, or is carpeted; and
 - b. If there are public restrooms that require mopping and cleaning on a particular floor.

(10) Urinal Substitution. A urinal may be substituted for a water closet for males if the substituted urinals do not exceed one third (1/3) of the required number of water closets for males.

(11) Public Facilities.

(a) Sanitary facilities shall be provided for the public if the building contains 5,000 square feet or more.

(b) In a mall or shopping center, the required facilities, based on one (1) person per 100 square feet of total area, shall be installed in individual stores or in a central toilet room area or areas, if:

1. The distance from the main entrance of a store does not exceed 500 feet; and
2. The toilet room area is accessible to physically disabled persons.

Section 2. Toilet Floor Construction Requirements.

(1) Floors in toilet rooms shall be constructed of nonabsorbent materials.

(2) If a wood floor is used, the wood floor shall be covered by other nonabsorbent materials.

(3) If two (2) or more fixtures that receive human waste are installed and a wood floor is not used, the toilet room shall have at least:

- (a) One (1) floor drain; and
- (b) One (1) accessible hose bibb.

Section 3. Fixture Requirements.

(1) The following chart shall provide the water closet, lavatory, drinking fountain, and urinal requirements for different occupancy groups.

Occupancy Group	Examples	Water Closet (males) ^a	Water Closet (females) ^a	Lavatories (male) ^a	Lavatories (female) ^a	Drinking Fountain	Urinals (males) ^a
A-1	Theaters, movie theaters, and similar buildings	1 per up to 100; 2 for 101 to 200; 3 for 201 to 400; 1 per additional 500 afterwards	1 for up to 50; 2 for 51 to 100; 3 for 101 to 150; 4 for 151 to 200; 1 per additional 150 afterwards	1 for up to 100; 2 for 101 to 200; 3 for 201 to 400; 4 for 401 to 750; 1 per each 500 afterwards	1 for up to 100; 2 for 101 to 200; 3 for 201 to 400; 4 for 401 to 750; 1 per each 500 afterwards	1 per 500 on every floor	1 for 11 to 100; 2 for 101 to 300; 3 for 301 to 600; and 1 for each additional 300 afterward
A-2	Banquet halls, casinos, dance halls, nightclubs, restaurant cafeterias, taverns, and bars	1 per up to 200; 2 for 201 to 400; 1 per additional 200 afterwards	1 per up to 100; 2 for 101 to 200; 1 per additional 200 afterwards	1 per 200	1 per 200	1 per 100 unless water stations are provided	1 for 50 to 200; 1 per additional 150 afterwards
A-3	Libraries, museums, and art galleries	1 per 200	1 per 100	1 per 200	1 per 100	1 per 500	1 for 11 to 200; 2 for 201 to 400; 3 for 401 to 600; and 1 for each additional 300 afterward
	Assembly halls and similar buildings	1 per up to 100; 2 for 101 to 200; 3 for 201 to 400; 1 per additional 500 afterwards	1 for up to 50; 2 for 51 to 100; 3 for 101 to 150; 4 for 151 to 200; 1 per each additional 150 afterwards	1 for up to 100; 2 for 101 to 200; 3 for 201 to 400; 4 for 401 to 750; 1 per each 500 afterwards	1 for up to 100; 2 for 101 to 200; 3 for 201 to 400; 4 for 401 to 750; 1 per each 500 afterwards	1 per 500 on every floor	1 for 11 to 100; 2 for 101 to 300; 3 for 301 to 600; and 1 for each additional 300 afterward
	Places of worship	1 per 300	1 per 150	1 per 200	1 per 200	1 per 400	1 for 50 to 150; 1 for each additional 150 afterwards
A-4	Structures for indoor sporting events and activities	1 for 100; 2 for 101 to 200; 3 for 201 to 400; 1 per additional 500 afterwards	1 for 50; 2 for 51 to 100; 3 for 101 to 150; 4 for 151 to 200; 1 per each 150 afterwards	1 for up to 100; 2 for 101 to 200; 3 for 201 to 400; 4 for 401 to 750; 1 per each 500 afterwards	1 for up to 100; 2 for 101 to 200; 3 for 201 to 400; 4 for 401 to 750; 1 per each 500 afterwards	1 per 500 on every floor	1 for 11 to 100; 2 for 101 to 300; 3 for 301 to 600; and 1 for each additional 300 afterward

Occupancy Group	Examples	Water Closet (males) ^a	Water Closet (females) ^a	Lavatories (male) ^a	Lavatories (female) ^a	Drinking Fountain	Urinals (males) ^a
A-5	Stadiums and other structures for outdoor sporting events and activities	1 for 100; 2 for 101 to 200; 3 for 201 to 400; 1 per additional 500 afterwards	1 for 50; 2 for 51 to 100; 3 for 101 to 150; 4 for 151 to 200; 1 per additional 150 afterwards	1 for up to 100; 2 for 101 to 200; 3 for 201 to 400; 4 for 401 to 750; 1 per each 500 afterwards	1 for up to 100; 2 for 101 to 200; 3 for 201 to 400; 4 for 401 to 750; 1 per each 500 afterwards	1 per 500 on every floor	1 for 11 to 100; 2 for 101 to 300; 3 for 301 to 600; and 1 for each additional 300 afterward
B	Swimming pool bathhouses Park service buildings or bathhouses	1 per 75	1 per 50	1 per 50	1 per 50	1 per 200	1 per 75
	See subsections (11) and (12) of this section						
	Office buildings c	1 for 1 to 15; 2 for 16 to 35; 3 for 36 to 55; 4 for 56 to 80; 5 for 81 to 110; 6 for 111 to 150; 1 for each additional 40 afterwards		1 for 1 to 15; 2 for 16 to 35; 3 for 36 to 60; 4 for 61 to 90; 5 for 91 to 125; 1 for each additional 75 afterwards		1 per 75	Optional
	Schools of higher-education and similar educational facilities	1 per 50	1 per 25	1 per 25	1 per 25	1 per 75	1 per 50
E	School buildings (not including higher-education facilities)	1 for up to 25; 2 for 26 to 100; 1 for each 100 afterwards	2 for up to 25; 3 for 26 to 50; 6 for 51 to 100; 8 for 101 to 200; 10 for 201 to 300; 12 for 301 to 400; 14 for 401 to 500; 1 additional for each 40 afterwards	1 per 25 up to 50; 1 per 50 afterwards	1 per 25 up to 50; 1 per 50 afterwards	See subsection (10) of this section	1 for 1 to 25; 2 for 26 to 50; 4 for 51 to 100; 6 for 101 to 200; 8 for 201 to 300; 10 for 301 to 400; 12 for 401 to 500; 1 for each additional 50 afterwards

Occupancy Group	Examples	Water Closet (males) ^a	Water Closet (females) ^a	Lavatories (male) ^a	Lavatories (female) ^a	Drinking Fountain	Urinals (males) ^a
M	Mercantile and retail food store	1 per 150 up to 450; 1 per each additional 500	1 per 100 up to 400; 1 per each additional 300	1 for 1 to 200; 2 for 201 to 400; 3 for 401 to 700; 1 for each additional 500	1 for 1 to 200; 2 for 201 to 400; 3 for 401 to 700; 1 for each additional 500	1 per 500 on each floor	1 for 50 to 200; 2 for 201 to 400; 3 for 401 to 600; 1 for each additional 300 afterwards
R-1	Transient lodging facilities (public service areas)	1 per 25	1 per 15	1 per 25	1 per 25	1 per 75 on each floor	1 for 11 to 100; for each additional 50 afterwards
	Transient lodging facilities (without private bath)	1 per 10; 1 per additional 25 afterwards	1 per 8; 1 per additional 20 afterwards	1 per 10	1 per 10	1 per 75 on each floor	1 for 11 to 100; 1 for each additional 50 afterwards
R-2 c	Dormitories, fraternities, sororities, and rooming houses	1 per 10		1 per 10		1 per 75	Optional
R-3 c	Congregate living facilities with 16 or fewer persons	1 per 10		1 per 10		1 per 75	Optional
R-4 c	Congregate living facilities with 16 or fewer persons	1 per 10		1 per 10		1 per 75	Optional
I-1	Residential Care	1 per 10	1 per 10	1 per 10	1 per 10	1 per 100 on each floor	1 for each 50
I-2	Hospitals wards and nursing home wards	1 per 10	1 per 10	1 per 10	1 per 10	1 per 100 on each floor	1 for each 50
	Hospital individual rooms and nursing home individual rooms	1 per room		1 per room		Optional	Optional

Occupancy Group	Examples	Water Closet (males) ^a	Water Closet (females) ^a	Lavatories (male) ^a	Lavatories (female) ^a	Drinking Fountain	Urinals (males) ^a
I-3	Institutions, penal (Cells) ^c	1 prison-type water closet per cell		1 prison-type lavatory per cell		Optional	Optional
	Institutions, penal. (Day rooms and dorms)	1 per 12	1 per 8	1 per 12	1 per 12	1 per floor	Optional
I-4	Adult day care and child day care	1 per 10	1 per 10	1 per 10	1 per 10	1 per 100 on each floor	1 for each 50
F-1 and F-2	Workshops and factories	1 for 25 to 100; 1 for each additional 30 afterwards	1 for 15 to 100; 1 for each additional 30 afterwards	1 for 25 to 100; 1 for each additional 50 afterwards	1 for 25 to 100; 1 for each additional 50 afterwards	1 for 50 to 100 on each floor; 1 for each additional 75 afterwards	1 for 11 to 50; 2 for 51 to 100; 1 for each additional 100 afterward
S-2	Parking garages ^d	1	1	1	1	Optional	1

Notes: a. The ratio equals the number of fixtures per the number of male occupants or female occupants.
b. The ratio equals the number of fixtures per the total number of occupants.
c. Separate male and female water closets or male and female lavatories are not required in these occupancy types.
d. There are no minimum fixture requirements for Group S-1 or S-2 buildings except for the minimum fixture requirement for parking garages.

(2) Facilities for Stages.

- (a) A separate water closet and lavatory shall be provided for males and females in the stage area.
- (b) A drinking fountain shall be provided in the stage and auditorium area.

(3) Carryout food service facilities. A carryout food service operation shall be exempt from providing toilet facilities for the use of the carryout food service facility's patrons.

(4) Licensed food establishments. In all food establishments licensed by the Cabinet for Health and Family Services, Department for Public Health, the requirements of this subsection shall be met.

(a) Handwashing sinks.

- 1. All handwashing sinks shall have a minimum hot water temperature of 100 degrees Fahrenheit and a maximum hot water temperature of 120 degrees Fahrenheit.
- 2. Self closing faucets shall provide a flow of water for no less than fifteen (15) seconds from activation.
- 3. Placement of handwashing sinks shall be approved by the Cabinet for Health and Family Services, Department for Public Health pursuant to 902 KAR 45:005.

(b) A three (3) compartment sink used for washing utensils shall be required and shall drain by a direct connection with a minimum of a two (2) inch drain.

(c) Dishwashing or ware washing machines shall discharge indirectly through a three (3) inch open receptacle.

(d) Residential type dishwashing machines shall discharge:

- 1. Through an air gap device; or
- 2. Indirectly through a three (3) inch open receptacle.

(e) Sinks solely used for food preparation shall discharge by an indirect connection to a minimum three (3) inch trap.

(f) All hub drains, open receptacles, floor sinks, or other waste receptacles shall extend one (1) inch above the floor plane unless a full grate *or* a strainer is installed flush with the floor.

- (g) Mobile food units. Occupied mobile food units not located within an existing permitted food establishment shall:
1. Meet the requirements of this code.
 2. Have a waste tank no less than fifty (50) percent larger than the freshwater tank;
 3. Have a National Sanitary Foundation (NSF) approved freshwater tank for potable water; and
 4. Have a minimum of a three (3) compartment sink and one (1) hand sink.
- (5) A restaurant with an occupancy of one (1) to fifteen (15) persons shall:
- (a) Comply with the requirements for Group A-2 buildings; or
 - (b) Provide at least one (1) unisex facility consisting of one (1) water closet and one (1) lavatory.
- (6) Employee Facilities.
- (a)
 1. Sanitary facilities within each building shall be provided for employees, unless an exception is approved by the division.
 2. Examples of exceptions include buildings of nonoccupancy, such as storage buildings or guard houses. These buildings shall not be required to have sanitary facilities if no one is working in the buildings. For guard houses, if the guard's normal scope of work requires him or her to enter buildings that already have sanitary facilities, then the guard house is not required to also have these facilities.
 - (b) If more than five (5) persons are employed, separate facilities for each sex shall be provided.
 - (c) For a tenant space within a building of 3,000 square feet or less of total gross floor area, employee facilities shall not be required if adequate interior facilities are provided within a centralized toilet room area or accessible areas having a travel distance of not more than 500 feet within the building in which the tenant space is located.
- (7) Residential private rooms. Residential facilities in Group R-1, Group R-2, Group R-3, and Group R-4 that have a private bath attached to a private room shall have one (1) water closet, one (1) lavatory, and one (1) bathtub or shower.
- (8) Kitchen type sinks. An apartment unit or a condominium unit in Group R-2 or Group R-3 buildings shall have a kitchen type sink.
- (9) Waiting rooms. Waiting rooms in Group I-2 buildings and Group I-3 buildings shall provide at least one (1) water closet and one (1) lavatory.
- (10) School drinking fountains.
- (a) Group E (not including higher education facilities) buildings shall have the following:
 1. A minimum of two (2) water bottle filling stations in each school;
 2. A minimum of one (1) drinking fountain or water bottle filling station on each floor and wing of each school building; and
 3. A minimum of one (1) drinking fountain or water bottle filling station for every seventy-five (75) students projected to attend the school upon completion of the proposed construction.
 - (b) A drinking fountain shall be equipped with:
 1. A protective cowl; and
 2. The orifice, which shall be one (1) inch above the overflow rim of the fountain.
- (11) Park Service Buildings or Bathhouses. A park service building or bathhouse shall comply with the requirements established in 902 KAR 15:020 and this subsection.
- (a) Except for a self-contained recreational vehicle community, each park shall provide one (1) or more central service buildings containing the necessary toilet and other plumbing fixtures established in this section.
 - (b) Except for a self-contained recreational vehicle community, sanitary facilities shall be provided as follows:
 1. If there are one (1) to fifteen (15) vehicle spaces, there shall be for:
 - a. Males: At least one (1) water closet, one (1) urinal, one (1) lavatory, and one (1) shower; and
 - b. Females: At least one (1) water closet, one (1) lavatory, and one (1) shower;
 2. If there are sixteen (16) to thirty (30) vehicle spaces, there shall be for:

- a. Males: At least one (1) water closet, one (1) urinal, two (2) lavatories, and two (2) showers; and
- b. Females: At least two (2) water closets, two (2) lavatories, and two (2) showers;
- 3. If there are thirty-one (31) to forty-five (45) vehicle spaces, there shall be for:
 - a. Males: At least two (2) water closets, one (1) urinal, three (3) lavatories, and three (3) showers; and
 - b. Females: At least two (2) water closets, three (3) lavatories, and three (3) showers;
- 4. If there are forty-six (46) to sixty (60) vehicle spaces, there shall be for:
 - a. Males: At least two (2) water closets, two (2) urinals, three (3) lavatories, and three (3) showers; and
 - b. Females: At least three (3) water closets, three (3) lavatories, and three (3) showers;
- 5. If there are sixty-one (61) to eighty (80) vehicle spaces, there shall be for:
 - a. Males: At least three (3) water closets, two (2) urinals, four (4) lavatories, and four (4) showers; and
 - b. Females: At least four (4) water closets, four (4) lavatories, and four (4) showers;
- 6. If there are eighty-one (81) to 100 vehicle spaces, there shall be for:
 - a. Males: At least four (4) water closets, two (2) urinals, five (5) lavatories, and five (5) showers; and
 - b. Females: At least five (5) water closets, five (5) lavatories, and five (5) showers; and
- 7. If over 100 vehicle spaces are provided, there shall be provided at least:
 - a. One (1) additional water closet and one (1) additional lavatory for each sex per additional thirty (30) spaces or fraction thereof;
 - b. One (1) additional shower for each sex per additional forty (40) vehicle spaces or fraction thereof; and
 - c. One (1) additional urinal for males per additional 100 vehicle spaces or fraction thereof.

(12) Residential and Day Camp Sites. A residential or day camp site shall comply with the requirements established in 902 KAR 10:040 and this subsection.

- (a)
 - 1. Each residential camp site shall be provided with sanitary facilities for each sex as established in this subsection.
 - 2. A day camp shall:
 - a. Not be required to provide shower facilities; and
 - b. Provide all other sanitary facilities for each sex as established in this section.
- (b) Sanitary facilities shall be provided as follows:
 - 1. If there are one (1) to eighteen (18) persons served, there shall be for:
 - a. Males: At least one (1) water closet, one (1) urinal, one (1) lavatory, and one (1) shower; and
 - b. Females: At least two (2) water closets, one (1) lavatory, and one (1) shower;
 - 2. If there are nineteen (19) to thirty-three (33) persons served, there shall be for:
 - a. Males: At least two (2) water closets, one (1) urinal, two (2) lavatories, and two (2) showers; and
 - b. Females: At least two (2) water closets, two (2) lavatories, and two (2) showers;
 - 3. If there are thirty-four (34) to forty-eight (48) persons served, there shall be for:
 - a. Males: At least two (2) water closets, two (2) urinals, two (2) lavatories, and three (3) showers; and
 - b. Females: At least three (3) water closets, two (2) lavatories, and three (3) showers;
 - 4. If there are forty-nine (49) to sixty-three (63) persons served, there shall be for:
 - a. Males: At least three (3) water closets, two (2) urinals, three (3) lavatories, and four (4) showers; and

- b. Females: At least four (4) water closets, three (3) lavatories, and four (4) showers;
- 5. If there are sixty-four (64) to seventy-nine (79) persons served, there shall be for:
 - a. Males: At least three (3) water closets, three (3) urinals, three (3) lavatories, and five (5) showers; and
 - b. Females: At least five (5) water closets, three (3) lavatories, and five (5) showers;
- 6. If there are eighty (80) to ninety-five (95) persons served, there shall be for:
 - a. Males: At least four (4) water closets, three (3) urinals, four (4) lavatories, and six (6) showers; and
 - b. Females: At least six (6) water closets, four (4) lavatories, and six (6) showers; and
- 7. If over ninety-five (95) persons are served, there shall be provided at least:
 - a. One (1) additional water closet and one (1) additional lavatory for each twenty-five (25) persons or fraction thereof served;
 - b. One (1) additional shower for each twenty (20) persons or fraction thereof served; and
 - c. One (1) additional urinal for each additional fifty (50) males or fraction thereof.
- (c) Coed day camps with equal number of males and females shall meet the fixture requirements of Group E school buildings (not including higher-education facilities) in the chart in subsection (1) of this section.
- (d) Water closets may be substituted for urinals if facilities are to be used by both sexes.

Section 4 Fixture Alternatives.

- (1) Lavatory alternatives.
 - (a) If a gang sink is installed, twenty four (24) inches of the gang sink shall equal one (1) lavatory.
 - (b) If a circular sink is installed, eighteen (18) inches of the circular sink basin shall equal one (1) lavatory.
- (2) Urinal alternative. If a trough urinal is installed, twenty four (24) inches of the trough urinal shall equal one (1) urinal.

Section 5. Other Fixture Requirements.

- (1) Modular Classrooms. If detached modular classrooms are used, sanitary facilities shall not be required, if:
 - (a) The entrance of the modular classroom for elementary grades through the fifth grade is within a developed travel distance not to exceed 100 feet from the accessible entrance to the main structure or an approved central modular restroom;
 - (b) The entrance of the modular classroom for sixth grade and above is within a developed travel distance not to exceed 200 feet, from the accessible entrance to the main structure or an approved central modular restroom;
 - (c) The travel path meets the accessibility requirements established in the Kentucky Building Code, 815 KAR 7:120; and
 - (d) There are sufficient fixtures in the main structure to serve the entire capacity of the school, including the modular classrooms.
- (2) Laundry trays or clothes washers. Dormitories in Group R-2 shall have one (1) laundry tray or clothes washer for each fifty (50) persons or fraction thereof.
- (3) Shower and bath requirements. Bathing fixtures requirements are as follows:
 - (a) Transient lodging facilities with private baths shall have one (1) bathtub or shower per room.
 - (b) Dormitories, fraternities, sororities, and rooming houses in Group R-2 shall have:

1. One (1) bathtub or shower for each eight (8) persons or fraction thereof up to 150 persons; and
 2. If there are over 150 persons, one (1) additional bathtub or shower for each twenty (20) persons.
- (c) Swimming pool bathhouses shall have one (1) shower per each fifty (50) persons or fraction thereof;
1. Showers shall be supplied with water at a temperature of not less than ninety (90) degrees Fahrenheit and at a flow rate of at least three (3) gallons per minute.
 2. Thermostatic, tempering, or mixing valves shall be installed to prevent scalding of the bathers.
 3. The requirement relating to bathhouse toilet room and shower facilities may be waived if the facilities are available to pool patrons within 150 feet from the pool.
- (d) Groups F-1 and F-2 buildings shall provide one (1) shower for each fifteen (15) persons [person] or fraction thereof, exposed to skin contamination from irritating, infectious, or poisonous materials.
- (e) Group I-2 buildings shall have at least one (1) bathtub or shower for each fifteen (15) persons or fraction thereof. (7 Ky.R. 526; eff. 1-7-1981; Am. 8 Ky.R. 367; eff. 1-6-1982; 9 Ky.R. 837; eff. 2-2-1983; 10 Ky.R. 458; eff. 11-2-1983; 1018; eff. 3-31-1984; 12 Ky.R. 49; eff. 8-13-1985; 14 Ky.R. 1146; eff. 1-4-1988; 15 Ky.R. 613; 981; eff. 9-28-1988; 16 Ky.R. 2277; eff. 6-7-1990; 23 Ky.R. 1764; 2503; eff. 12-11-1996; 27 Ky.R. 236; 777; eff. 9-11-2000; 30 Ky.R. 2398; 31 Ky.R. 92; eff. 8-6-2004; TAm eff. 8-9-2007; 36 Ky.R. 218; 609; eff. 10-2-2009; 2135-M; 2327; 37 Ky.R. 375; eff. 6-23-2010; 39 Ky.R. 155; eff. 10-5-2012; 41 Ky.R. 183; 463; eff. 9-24-2014; 42 Ky.R. 2655, 2899; eff. 6-22-2016; 46 Ky.R.2558, 2942; eff. 7-28-2020.)

815 KAR 20:195. Medical gas piping installations.

RELATES TO: KRS 198B.050, 318.010, 318.134

STATUTORY AUTHORITY: KRS 198B.040(10), 318.130, 318.134(3)

NECESSITY, FUNCTION, AND CONFORMITY: KRS 318.130 requires the department to promulgate administrative regulations establishing the Kentucky State Plumbing Code to regulate plumbing. KRS 318.134(3) requires the department to establish a reasonable schedule of fees and charges to be paid for plumbing installation permits and the necessary inspections incident thereto. This administrative regulation establishes the requirements for medical gas piping installation.

Section 1. Standards and Procedures. (1) Installation standards. All new medical gas piping installation or an addition to an existing medical gas piping system shall comply with the applicable provisions of NFPA 99 Health Care Facilities Code.

(2) Permit required. A licensed master plumber shall apply for a permit to install medical gas piping prior to the installation. To obtain the permit, the master plumber shall:

- (a) Pay a fee of forty-five (45) dollars base permit for the medical gas system for each building;
- (b) Pay a fee of fifteen (15) dollars per opening; and
- (c) Identify the person who shall perform the installation.

(3) The person installing the medical gas piping shall be:

- (a) A certified medical gas installer as required by NFPA 99 Health Care Facilities Code; and
- (b) A licensed master plumber or journeyman plumber.

(4) Supervision by a master plumber. It shall be the responsibility of the licensed master plumber to ensure that the person doing the installation:

- (a) Is properly certified as required by NFPA 99 Health Care Facilities Code;
- (b) Uses the proper products and stores them correctly; and
- (c) Requests and receives all inspections at the initial pressure test for the complete system from a qualified plumbing inspector.

(5) Final approval. Upon completion of the installation, the master plumber shall furnish the division with certification from the medical gas system verdhbcifier as required by NFPA 99 Health Care Facilities Code.

Section 2. Incorporation by Reference. (1) "NFPA 99 Health Care Facilities Code, 2012 Edition, National Fire Protection Association, is incorporated by reference.

(2) This material may be inspected, copied, or obtained, subject to applicable copyright law, at the Department of Housing, Buildings and Construction, 500 Mero St., Frankfort, Kentucky 40601-5412, Monday through Friday, 8 a.m. to 4:30 p.m.

(3) A copy may also be obtained by contacting the National Fire Protection Association, 1 Batterymarch Park, P.O. Box 9101, Quincy, Massachusetts 02269-9101. (23 Ky.R. 2372; Am. 2746; eff. 1-9-97; 30 Ky.R. 2404; 31 Ky.R. 97 eff. 8-6-04; TAm eff. 8-9-2007; 35 Ky.R. 2613; 36 Ky.R. 103; eff. 7-29-2009; 39 Ky.R. 1509; 1887; eff. 4-5-2013; 41 Ky.R. 1204; 1796; eff. 3-6-2015; 42 Ky.R. 2661, 2904; eff. 6-22-2016; 46 Ky.R. 1693, 2449; eff. 6-2-2020.)

Useful Information

Angle of Bend

60 – Degree
 45 – Degree
 30 – Degree
 22½ – Degree
 11¼ – Degree
 5 5/8 – Degree

Arc of Circle

1/6th
 1/8th
 1/12th
 1/16th
 1/32nd
 1/64th

To find the length of a forty-five degree offset: Multiply the distance between the two parallel lines by the constant 1.414.

For offsets that are not greater than 3 feet: The following is a good rule for 45-degree offsets, but not close enough for long offsets. Add to the distance between the two parallel lines pipe, 5 inches for each foot of such distance, and at the same rate for fractional parts of a foot. This would mean the addition of 5/12th of an inch for each inch. To be more exact, add 12/32nd of an inch to each inch distance between the two lines of pipe.

Table of Pipe Offset Constants

Fitting	Angle	Constant
1/64 th Bend	5 5/8 – Degree	10.203
1/32 nd Bend	11¼ – Degree	5.125
1/16 th Bend	22½ – Degree	2.613
1/12 th Bend	30 – Degree	2.000
1/8 th Bend	45 – Degree	1.414
1/6 th Bend	60 – Degree	1.155

Decimal Equivalents

Fractions of an inch	Decimals of an inch	Decimals of a foot
1/6"	.063"	.005'
1/8"	.125"	.010'
3/16"	.188"	.016'
1/4"	.250"	.021'
5/16"	.313"	.026'
3/8"	.375"	.031'
7/16"	.438"	.037'
1/2"	.500"	.042'
9/16"	.563"	.047'
5/8"	.625"	.052'
11/16"	.688"	.057'
3/4"	.750"	.063'
13/16"	.813"	.068'
7/8"	.875"	.073'
15/16"	.938"	.078'

The weight of one US gallon of water is 8 1/3 lbs.

One cubic foot contains 7.48 US gallons.

Pressure per square inch of a column of water is 0.434 X height in feet.

To find the pressure in pounds per square inches at the base of a column of water: Multiply the head or height in feet by .434.

To find the head, when pressure per square inch is known: Divide the pressure by .434.

To find the volume of any rectangular or a cylindrical tank: Multiply the area of the base X height.

To find the volume of a rectangular tank: Multiply length X width X height.

To find the volume of a cylindrical tank: Multiply $R^2 \times 3.1416 \times \text{Height}$ or $D^2 \times .7854 \times \text{height}$.

To find the volume of a rectangular or cylindrical tank in US gallons: When dimensions are given in inches, divide the number of cubic inches by 231.

To find the volume of a cylindrical or rectangular tank in US gallons: When dimensions are given in feet, multiply the number of cubic feet X 7.48.

To find the cubic contents of any length of pipe of any size: First find the cubic contents of one foot of pipe, and then multiply that amount by the number of feet of pipe. If these dimensions are in inches, the result will be in cubic inches. If the result desired is gallons, as it generally will be divide the result in cubic inches by 231, there being 231 cubic inches in one gallon.

A short method of finding the number of gallons in a foot of pipe of a diameter: Multiply the square of the inside diameter of the pipe by .0408.

Rule for Estimating the Pitch of a Pipe: Divide the total drop or fall of the pipe, measured in inches, by the horizontal distance between the two ends of the pipe, measured in feet. The result will give the pitch per feet in fractions of an inch.

To find the circumference of a circle: Its diameter being given, multiply the diameter by 3.1416. The product will be the circumference.

To find the diameter of a circle the circumference being known: Divide the circumference by 3.1416. The result will be the diameter.

To find the area of a circle when the diameter is known: Square the diameter and then multiply by .7854.

Circumference of Circle = 3.1416 X Diameter

Area of Circle = 3.1416 X Square of Radius

To find the cylindrical area of a cylinder: Multiply the circumference of a circle by the length of the cylinder.

To find the cubic content of a cylinder: Multiply the area of its circle by the length of the cylinder.

To change a common fraction to a decimal: Divide the numerator by the denominator, and point off the right number of decimal places.

To add decimals: Arrange the numbers so that the decimal points are in line, and then carry out the addition as for whole numbers.

To multiply two decimals: Arrange the two numbers regardless of the location of their decimal points. The multiplication of the numbers proceeds exactly as in the case of multiplying two whole numbers together. The proper location of the decimal point in the answer is determined by the following: In the product of the two numbers the decimal point should have as many numbers to the right of it as the sum of the numbers to the right of the decimal points of the two numbers that are multiplied together.

To divide two decimal numbers: Divide the two numbers without regard to the two decimal points. Just as in the division of two whole numbers, subtract from the number of decimal places in the dividend the number of the decimal places in the divisor and the remainder will be the correct number of figures to the right of the decimal point in the quotient, which will be the answer required.

To change per cent into a common fraction: Write the number expressing the per cent as the numerator with 100 as the denominator. Often such a fraction may be simplified by reducing it to its lowest terms.

To change a number written with a per center sign into a decimal: Omit the per cent sign and move the decimal point two places to the left.

To change a decimal to per cent: Shift the decimal point two places to the right.

To change a common fraction into per cent: Reduce the fraction to hundredths, omit the denominator and place the per center sign after the numerator.

To find a required per cent of a number: Multiply the number by the given per cent.

In this method, the number below the line shows the number of equal parts into which the whole is divided and is call the denominator. The number of equal parts taken is shown above the line and is called the numerator. According in speaking of $\frac{3}{4}$ of a pound, the denominator, 4 shows the pounds divided into four equal parts and the numerator, 3 shows that three of these four parts are taken or set aside for some special purpose.

A fraction can be changed to higher terms (without changing its value) by multiplying both numerator and denominator by the same number and to lower terms, (without changing its value) by dividing both numerator and denominator by the same number.

To reduce a mixed number to an improper fraction: Multiply the whole number by the denominator of the fraction, then add the numerator to the result and place the result over the denominator.

To reduce two or more fractions to fractions having a common denominator: After deciding what the common denominator is to be, multiply each of the several numerators by the number of times its denominator is contained in the common denominator.

To add two or more fractions: Reduce the fraction to fractions having a least common denominator. Then add the numerators of the fractions and place the sum over the common denominator, this fraction will be the answer required.

To subtract fractions: Reduce them to fractions having a common denominator. Then, if necessary reduce the result to its lowest terms and in the case of an improper fraction reduce it to a mixed number.

When mixed numbers are to be subtracted: Subtract the fractions and the whole numbers separately.

When the smaller mixed number is a larger fraction than the larger mixed number: Borrow 1 from the whole number of the larger mixed number and add it to its fraction and then proceed to subtract.

When the larger number is a whole number and smaller is a mixed number: Borrow 1 from the whole number.

In cancellation, any factor above the line may be divided (if without remainder) into any factor below the line and any factor below the line may be divided into any factor above the line Multiply together the numbers remaining above the line for the numerator and the number remaining below the line for the denominator. If no number remains above the line, use 1.

To multiply a fraction by a fraction: Multiply the numerator together for the numerator of the answer and the denominators together for the denominator of the answer. Cancel whenever possible.

Method of Making a Square

Nail together two straight pieces of 1 x 2 board to form an L as shown in Figure 25.

Mark off a point 3 feet from the corner on one of the boards.

Mark off a point 4 feet from the corner of the other board.

Cut another board exactly 5 feet long. Line up this board with the points marked on the other two boards.

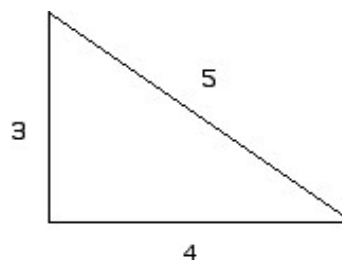

NOTE: These measurements can have doubled to make a larger square or they may be cut in half to make a smaller square.

Capacities of Tanks

Cylindrical Tanks

Formulas:

C = capacity in gallons

D = diameter

L = length

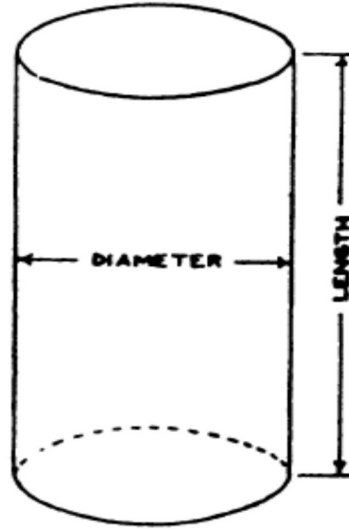

Fig. 14. Cylindrical tank.

When measurements are in inches:

$$C = \frac{D \times D \times 0.7854 \times L}{231}$$

When measurements are in feet:

$$C = D \times D \times 0.7854 \times L \times 7.48$$

Example:

How many gallons of water will a tank hold which is 3 feet in diameter and 12 feet long?

$$C = D \times D \times 0.7854 \times L \times 7.48$$

$$C = 3 \times 3 \times 0.7854 \times 12 \times 7.48 = 634.477 \text{ or } 634 \frac{1}{2} \text{ gallons}$$

To find the volume of a rectangle tank: Multiply length x width x height.

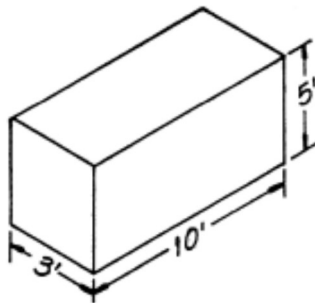

Example

$$10' \times 3' \times 5' = 150 \text{ cu. ft.}$$

10	150
<u>x 3</u>	<u>x 7.48</u>
30	1200
<u>x 5</u>	600
150	<u>1050</u>
	1122.00 gallons

To find the volume in US gallons: Multiply the number of cubic inches by 231

$$7.48 \text{ gallons} = 1 \text{ cubic foot} \quad 231 \text{ cubic inches} = 1 \text{ gallon}$$

Mechanical Engineers and Architectural blueprints usually give the city sewer main and the building drain invert elevation (inside bottom of the barrel) in feet and decimals of a foot.

Plumbers work with feet and inches of a foot; therefore, plumbers must change feet and decimals of a foot to feet and inches.

Example

The invert elevation at the city main is given as 84.25' and the building drain is given as 86.75'.

$$\begin{array}{r} \text{Total fall} = \quad 86.75' \quad .50 \\ \quad \quad \quad - 84.25' \quad \underline{x 12} \\ \quad \quad \quad 2.50' = 2' 6'' \quad 100 \\ \quad \quad \quad \quad \quad \quad \underline{50} \\ \quad \quad \quad \quad \quad \quad 6.00 \end{array}$$

First find the cubic contents of one foot of the pipe, then multiply that amount by the number of feet of pipe. If these dimensions are in inches, the result will be cubic inches. If the result desired is gallons, as it generally will be, divide the result in cubic inches by 231, there being 231 cubic inches in one gallon.

Example How many gallons will a 3/4" pipe 50' long contain?

$$\begin{array}{r} .75 \quad \quad \quad .4417875 \quad \quad \quad \underline{.022950} \\ \underline{x .75} \quad \quad \quad \underline{x 12} \quad 231 \mid 5.3014500 \quad \quad \quad .022950 \\ 375 \quad \quad \quad 8835750 \quad \quad \quad \underline{4 62} \quad \quad \quad \underline{x 50} \\ \underline{525} \quad \quad \quad \underline{4417875} \quad \quad \quad 681 \quad \quad \quad 1.147500 \text{ gals.} \\ 5625 \quad \quad \quad 5.3014500 \quad \quad \quad \underline{462} \\ \quad \quad \quad \quad \quad \quad 2194 \\ \quad \quad \quad \quad \quad \quad \underline{2079} \\ \text{Note: } D^2 \times .7854 \times 12 \quad 3/4'' = .75 \quad \quad \quad 1155 \\ \quad \quad \quad \quad \quad \quad \underline{1155} \\ \quad \quad \quad \quad \quad \quad 0 \end{array}$$

Rules for estimating the pitch of a pipe:

Divide the total drop or fall of the pipe, measured in inches by the horizontal distance between the two ends of the pipe measured in feet. The result will give the pitch per feet in fractions of an inch.

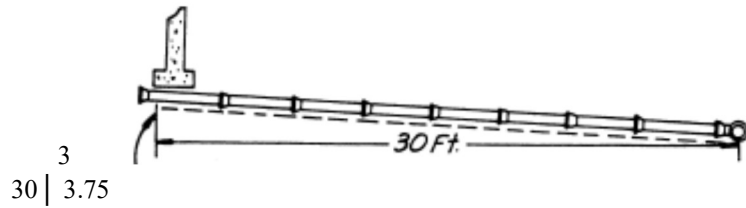

Total Drop
.125 or 1/8" per ft.
 3/4" or 3.75

30
 75
60
 150
150
 0

Pitch to Grade

<u>Pitch</u>	<u>Grade</u>
1/16"	1/2 %
1/8"	1%
1/4"	2%
1/2"	4%

To find the pressure in pounds per square inch at the base of a column of water:

Multiply the head or the height in feet by .434

Example

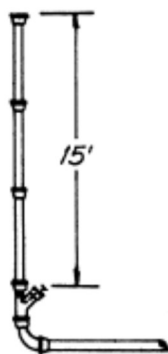

15' x .434 = 6.51 lbs.
 Or 6 1/2 lbs.

.434
x 15
 2170
434
 6.510

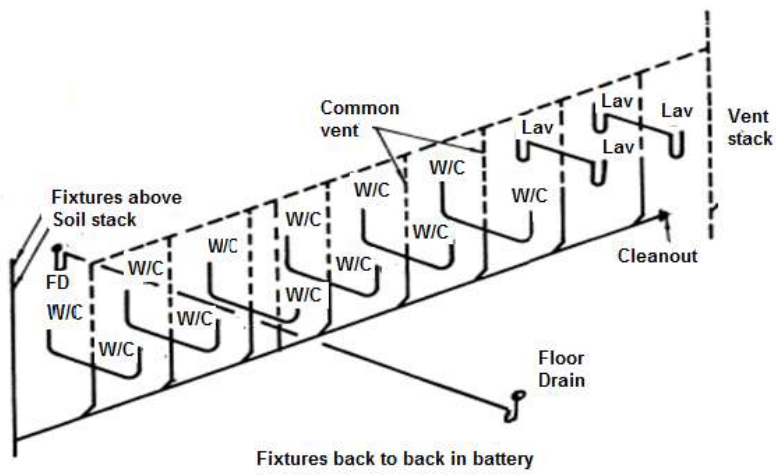

Loop Vent

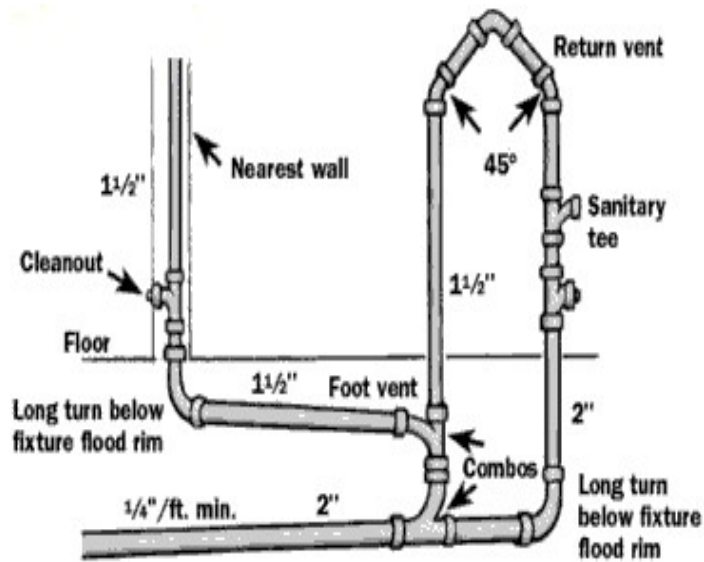

3 Compartment sink and grease trap installation

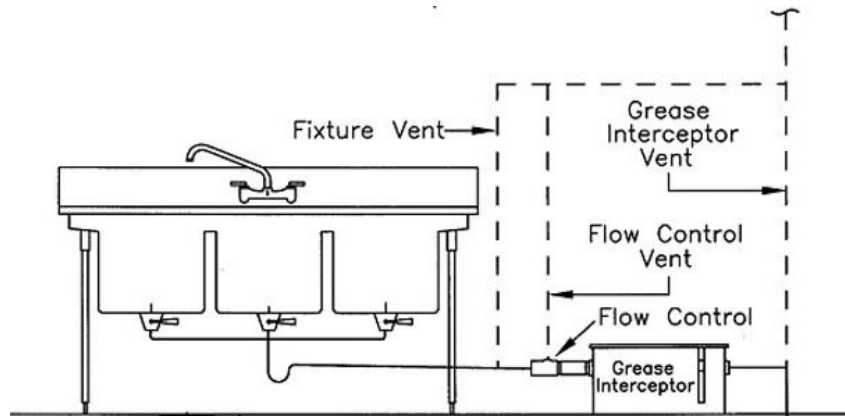

VERTICAL INSTALLATION

Thermal Expansion and Contraction may be controlled by Offsets, expansion joints and restraints

Piping shall not to be anchored rigidly to allow for movement from expansion and contraction.

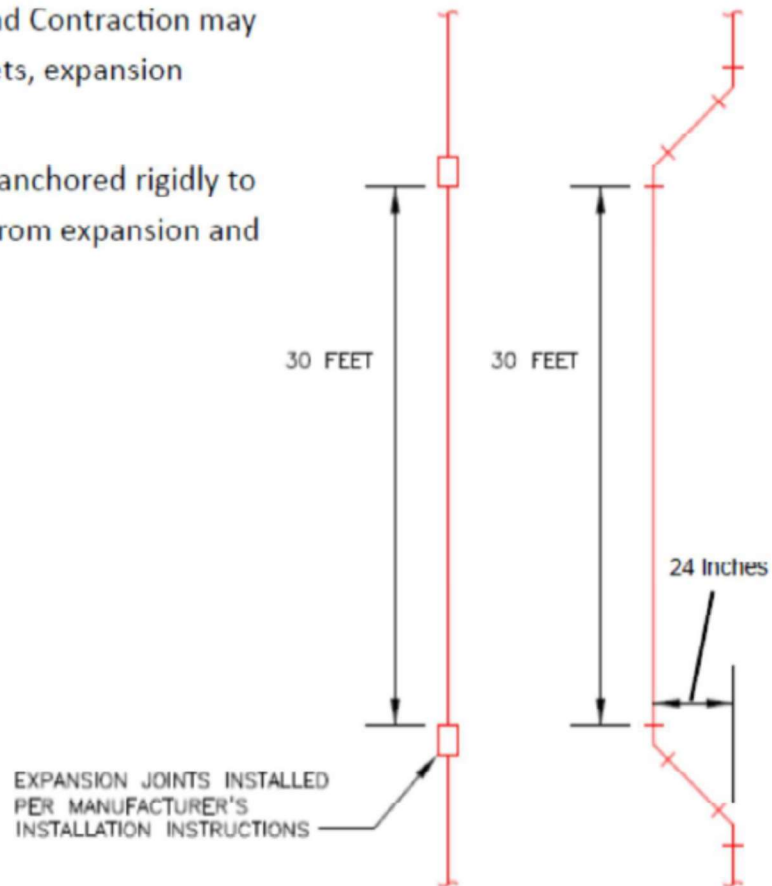

Your text here

Typical Installation

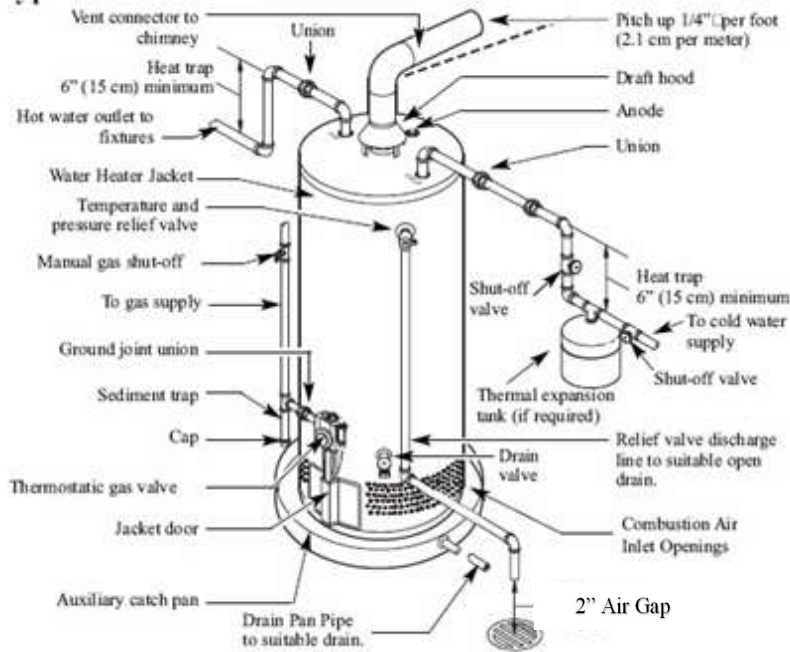

Typical Installation

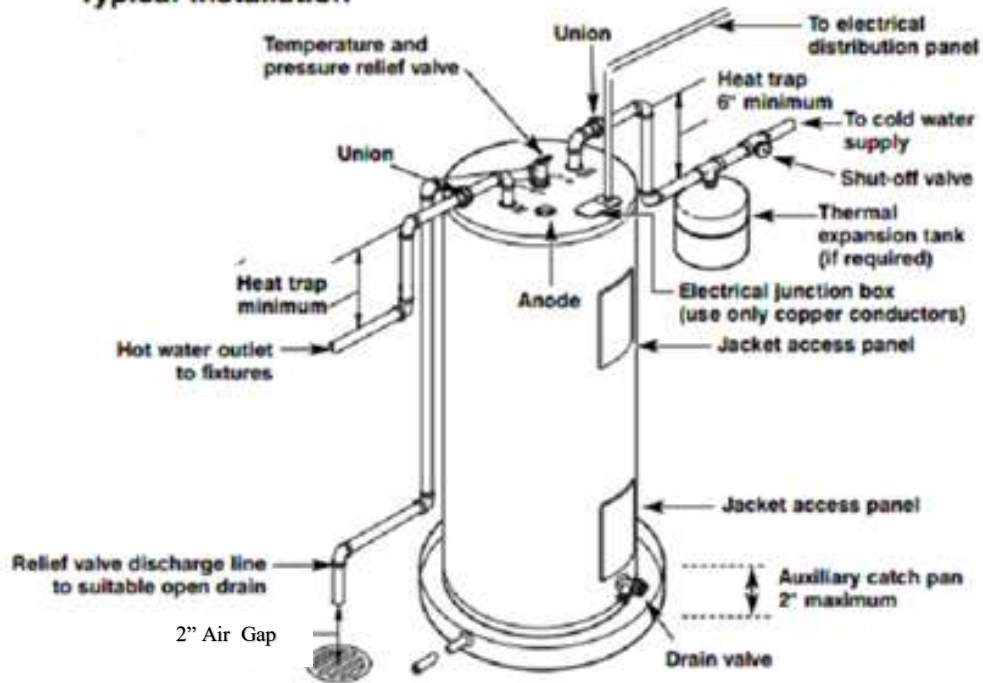

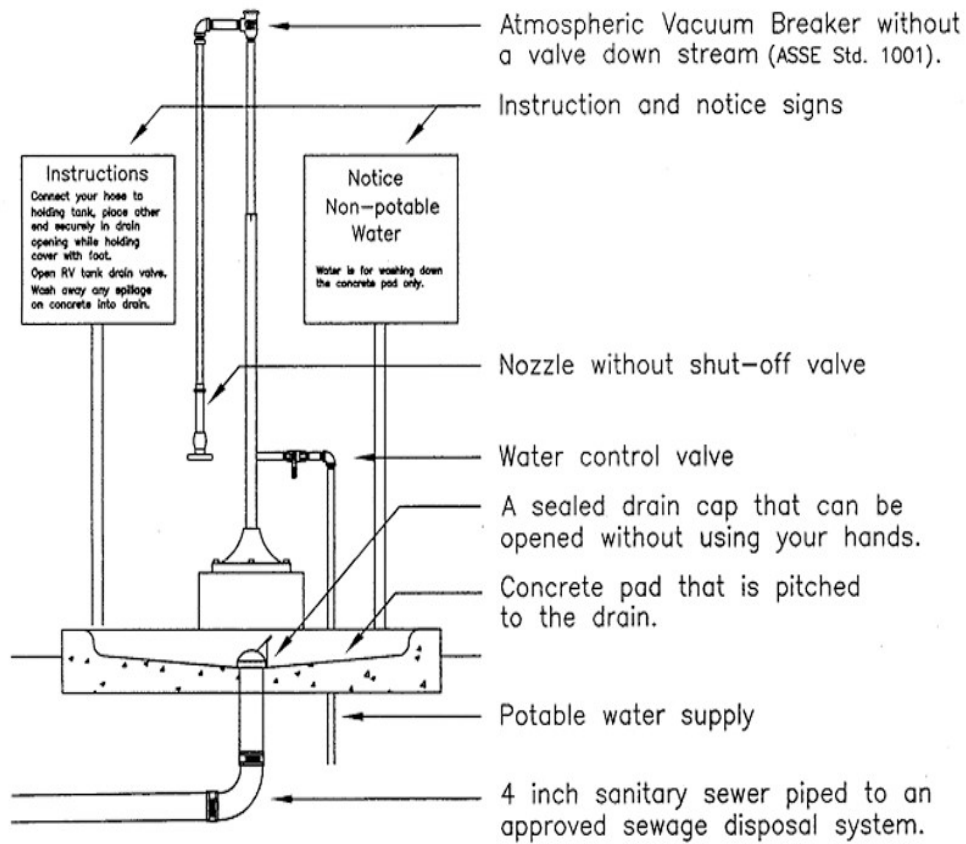

Elevation View

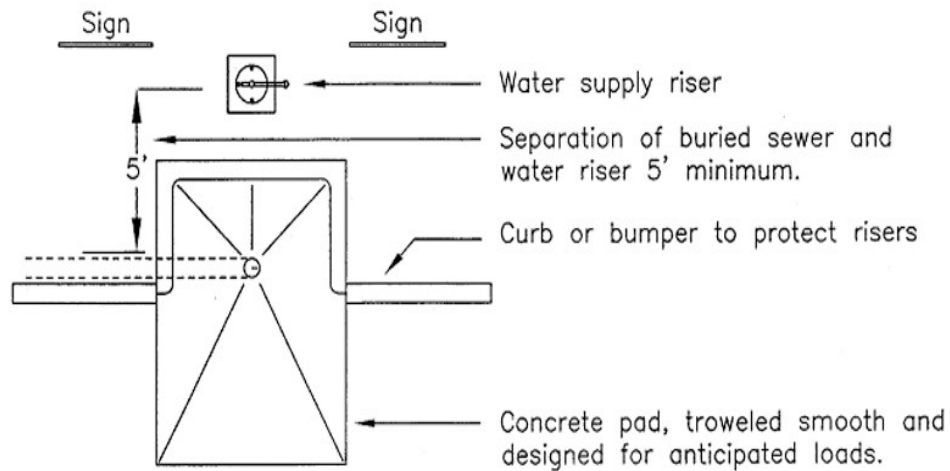

Plan View

Travel Trailer Dump Station

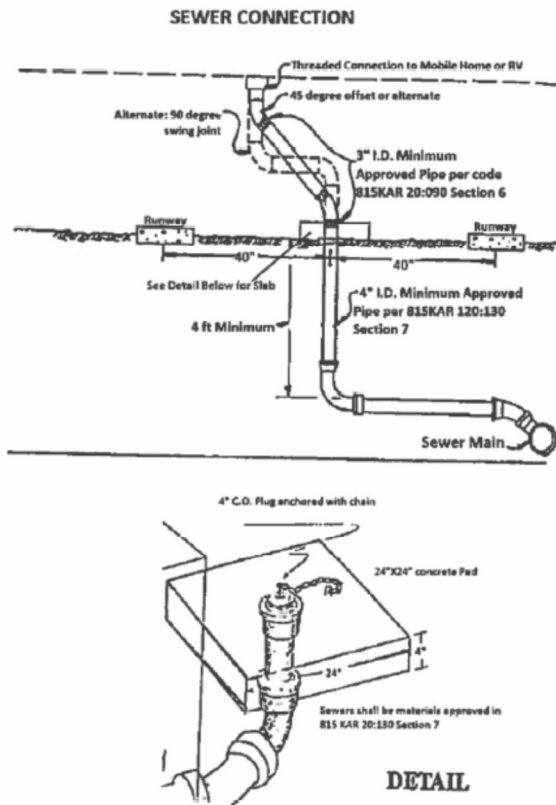

Mobile Home and RV Sewer Connection

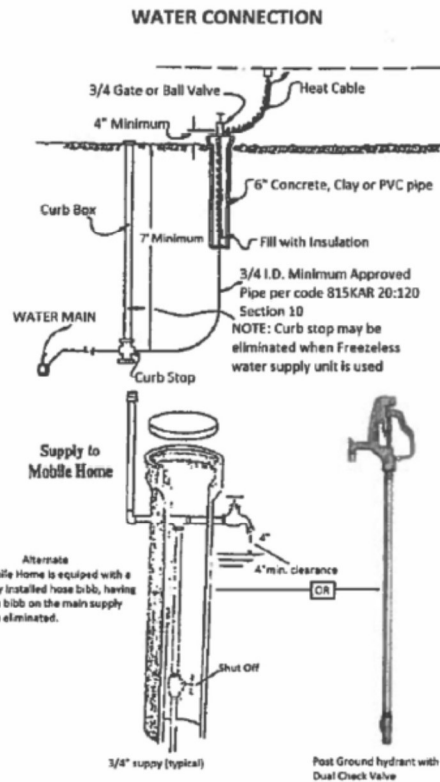

Mobile Home and RV Water Connection

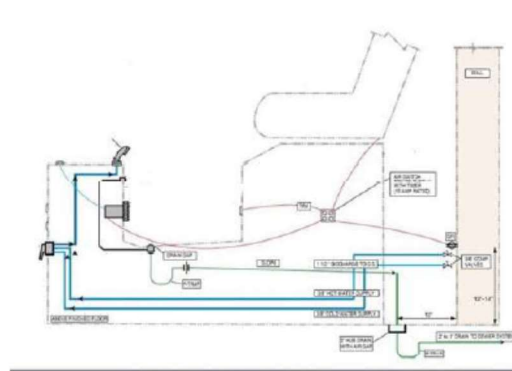

Pedicure Chairs

1. A two (2) inch open receptacle may receive the discharge from up to two (2) pedicure chairs.
2. Three (3) inch open receptacle may receive the discharge from three (3) to six (6) pedicure chairs.
3. Pump discharge: each pump discharge shall be individually piped to an open receptacle.
4. If the water inlet for a pedicure chair is below the flood level rim or is equipped with a spray hose, it will be treated as HIGH HAZARD and shall require a reduced pressure principle backflow preventer on both hot and cold water supply.

Note: The grated drain is not trapped. The separator is the trap.

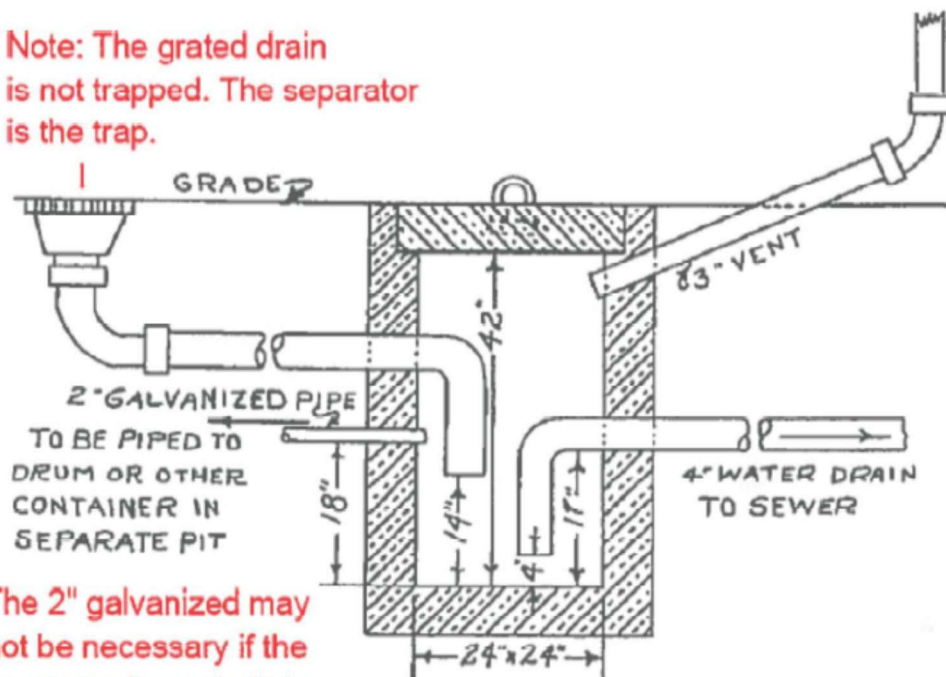

The 2" galvanized may not be necessary if the separator has a built in reservoir.

GARAGE
CESSPOOL OIL SEPARATOR

Installation for back to back power flush WC

Combination Double Wye & 1/8 bend prevents syphonage

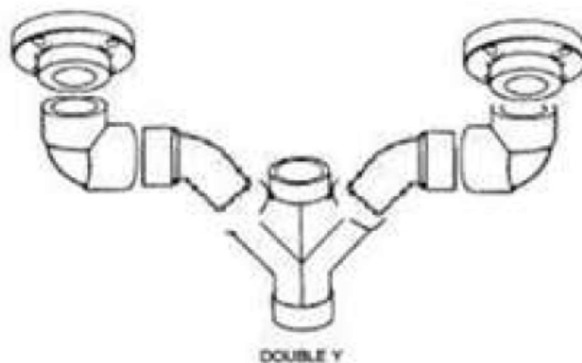

Per water closet manufactures instructions

Section 19. Distance of Trap from Vent. (1)(a) The distance between the vent and the fixture trap shall be measured along the center line of the waste or soil pipe from the vertical inlet of the trap to the vent opening.
 (b) The fixture trap vent, except for a water closet or a similar fixture, shall not be below the dip of the trap, and each ninety (90) degree turn in the waste line of the main waste, soil, or vent pipe shall be washed.

Manufactured floor drain system

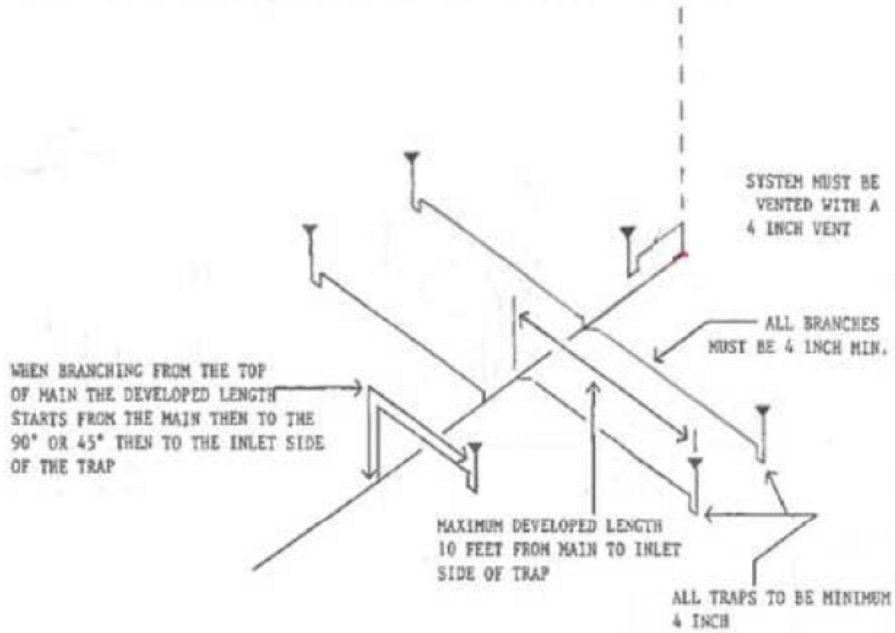

Combination hub & floor drains

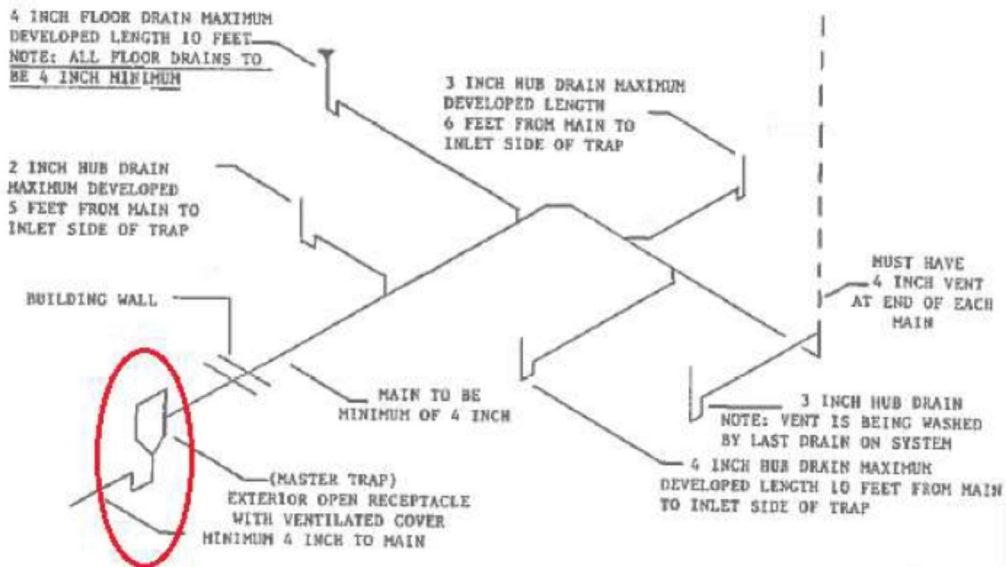

Note: Sinks of any type cannot be added to these systems